

multiPort Floppy Drive

User's Manual

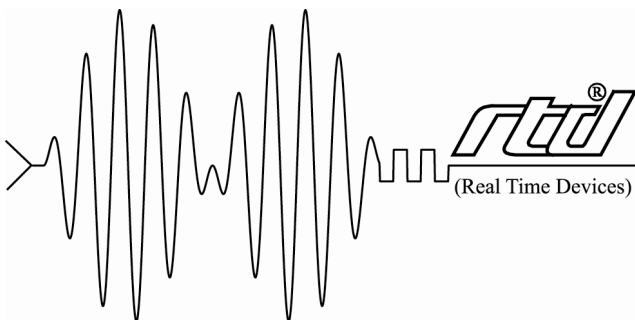

RTD Embedded Technologies, Inc.

"Accessing the Analog World"®

BDM-610040005
Rev. A

ISO9001 and AS9100 Certified

multiPort Floppy Drive



RTD EMBEDDED TECHNOLOGIES, INC.

103 Innovation Blvd
State College, PA 16803-0906

Phone: +1-814-234-8087
FAX: +1-814-234-5218

E-mail
sales@rtd.com
techsupport@rtd.com

Web Site
<http://www.rtd.com>

Manual Revision History

Rev A Initial Release

Published by:

RTD Embedded Technologies, Inc.
103 Innovation Boulevard
State College, PA 16803

Copyright 2005 by RTD Embedded Technologies, Inc.
All rights reserved.

The RTD Embedded Technologies Logo is a registered trademark of RTD Embedded Technologies. dspModule, cpuModule, and utilityModule are trademarks of RTD Embedded Technologies. PC/104, PC/104-*Plus*, and PCI-104 are registered trademark of PC/104 Consortium. All other trademarks appearing in this document are the property of their respective owners.

Table of Contents

Introduction	5
Product Overview	5
Board Features	5
Floppy Drive Features	5
Physical Attributes	5
Available Options	5
XK-CM49	5
IDAN-IFK-3	5
Getting Technical Support	6
Board Hardware.....	7
Connector and Jumper Locations	7
Jumpers	7
JP2 – Pullup Options Jumper (Default = 3-4)	7
External I/O Connections	8
Drive Power In	8
multiPort Connectors	8
Drive Power Out	9
Floppy Signals Connector	9
Board Installation.....	10
Installing the Hardware	10
Static Precautions	10
Steps for Installing.....	10
BIOS Configuration	10
Limited Warranty.....	11

Introduction

Product Overview

The multiPort Floppy Drive is designed to provide floppy drive support to the RTD line of cpuModules. Selected cpuModules are capable of providing the floppy drive signals on the parallel port connector, or “multiPort.” This floppy drive then attaches to the multiPort. There is no software or BIOS emulation, so the floppy drive appears to the operating system as a standard floppy drive.

Board Features

Floppy Drive Features

- Standard Floppy Drive interface can be used with any operating system
- Includes Floppy Drive and all required cables.
- Can be mounted in a 3.5” drive bay

Physical Attributes

- Cable Length: 12 inches
- Size: 6.00”L x 4.00”W x 1.00”H (152mm L x 102mm W x 25mm H)
- Weight: 1.0 lbs (454 g)
- Operating Temperature: 4° C to +50° C
- Storage Temperature: -22° C to +60° C
- Power Requirements:
 - Max: 5.5 W @ +5 VDC
 - Typical: 3.0 W @ +5 VDC

Available Options

The multiPort Floppy Drive is available in the following cable kits.

XK-CM49

- Configured for “bare board” applications
- Includes cable to attach to 26-pin, 0.100” DIL multiPort
- Includes cable to attach to 26-pin, 2mm DIL multiPort
- Includes power cable

IDAN-IFK-3

- Configured for IDAN applications.
- Includes cable to attach to DB-25 multiPort
- Includes power cable

Getting Technical Support

For help with this product, or any other product made by RTD, you can contact RTD Embedded Technologies via the following methods:

Phone: +1-814-234-8087

E-Mail: techsupport@rtd.com

Be sure to check the RTD web site (<http://www.rtd.com>) frequently for product updates, including newer versions of the board manual and application software.

Board Hardware

Connector and Jumper Locations

The following diagram shows the location of all connectors and jumpers on the multiPort Floppy Drive. For a description of each jumper and connector, refer to the following sections.

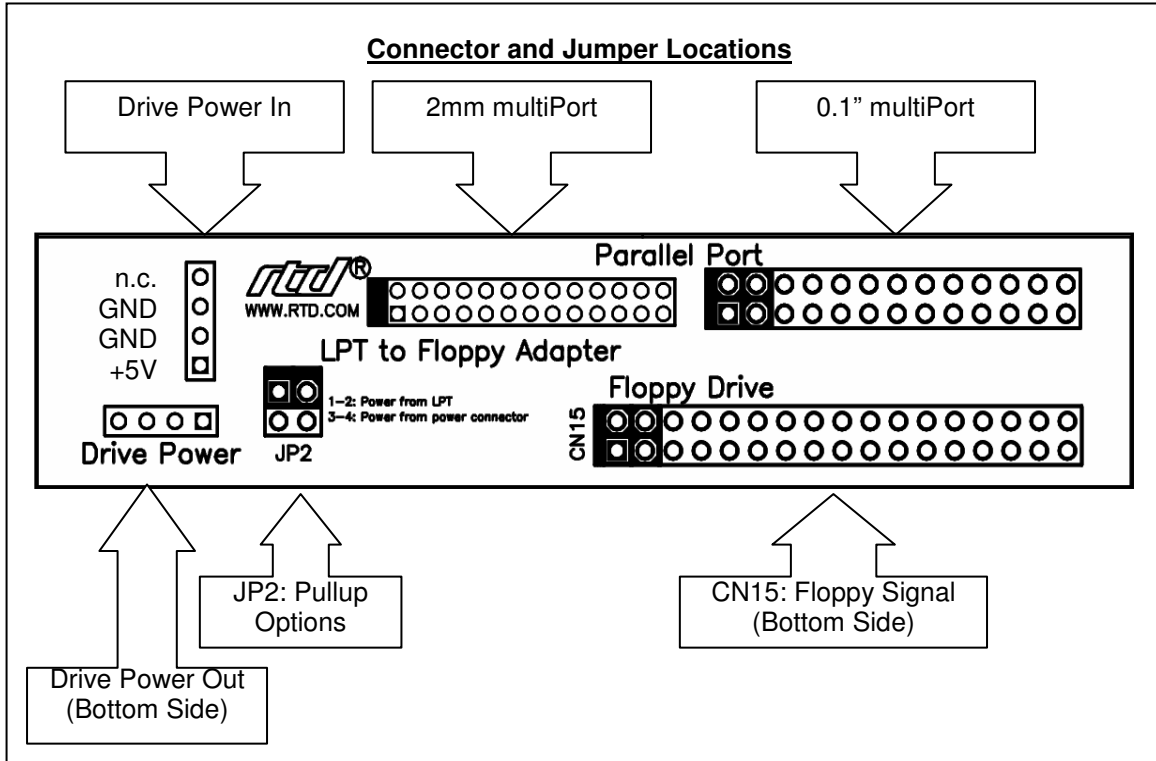

Jumpers

The following sections describe the jumper configuration options available on the multiPort Floppy Drive.

JP2 – Pullup Options Jumper (Default = 3-4)

Several of the floppy drive signals require pullup resistor in order to operate properly. These pullup resistors are provided on the multiPort Floppy Drive board. They can be powered either from the floppy drive power connector, or from the power signal on the multiPort. The default configuration should be used for all applications.

JP2	Description
1-2	Pullups powered from multiPort
3-4	Pullups powered from power connector (default)

External I/O Connections

The following sections describe the external I/O connections of the multiPort Floppy Drive.

Drive Power In

This connects to a standard floppy drive power connector. It supplies power to the drive, and can also supply power to the on-board pull-up resistors. The pin assignments for the power connector are:

Note: Pin 1 can be identified by a square solder pad.

Pin	Signal	Wire Color
1	+5V	Red
2	GND	Black
3	GND	Black
4	12V(n.c.)	Yellow

multiPort Connectors

Two connectors are provided for the multiPort to accommodate the full line of cpuModules. One connector has 0.1" pin spacing and the other has 2mm pin spacing. Only one connector should be used at a time. The pin assignments are the same for both, and are as follows:

Note: Pin 1 can be identified by a square solder pad. Pins 2 – 10 have round solder pads.

Pin	DB25	Function
1	1	-
2	14	DR0
3	2	INDEX#
4	15	HDSEL#
5	3	TRK0#
6	16	DIR#
7	4	WRTPRT#
8	17	STEP#
9	5	RDATA#
10	18	GND
11	6	DSKCHG
12	19	GND
13	7	-
14	20	GND
15	8	-
16	21	GND
17	9	-
18	22	GND
19	10	DS1#
20	23	GND
21	11	MTR#
22	24	GND
24	25	GND
25	13	WGATE#
26	-	+5V

Drive Power Out

This connector mates to the power connector on the floppy drive. It is a direct connection to the Drive Power In connector.

Floppy Signals Connector

This is a standard 34-pin floppy drive connector. It mates with the signal connector of the floppy drive. All of the signals for this connector are provided by the multiPort connector.

Board Installation

Installing the Hardware

The multiPort Floppy Drive can be attached to any RTD cpuModule that supports floppy through the multiPort. It can be attached either directly to the cpuModule, or to the multiPort connector on an IDAN frame.

Static Precautions

Keep your drive in its antistatic bag until you are ready to install it into your system! When removing it from the bag, hold the drive at the edges and do not touch the components or connectors. Handle the board in an antistatic environment and use a grounded workbench for testing and handling of your hardware.

Steps for Installing

1. Shut down the PC/104 system and unplug the power cord.
2. Ground yourself with an anti-static strap.
3. Set the jumpers as described in the previous chapter.
4. Attach the appropriate cable between the drive and the cpuModule.
5. Boot the system and setup the BIOS as described in the manual for the cpuModule.
6. Verify that all of the hardware is working properly.

BIOS Configuration

After physically installing the drive, the cpuModule BIOS must be configured to use it. The settings that need to be changed depend on the cpuModule used. Check the “multiPort: Floppy Controller Mode” section of the cpuModule manual for the appropriate setting for your cpuModule.

Limited Warranty

RTD Embedded Technologies, Inc. warrants the hardware and software products it manufactures and produces to be free from defects in materials and workmanship for one year following the date of shipment from RTD EMBEDDED TECHNOLOGIES, INC. This warranty is limited to the original purchaser of product and is not transferable.

During the one year warranty period, RTD EMBEDDED TECHNOLOGIES will repair or replace, at its option, any defective products or parts at no additional charge, provided that the product is returned, shipping prepaid, to RTD EMBEDDED TECHNOLOGIES. All replaced parts and products become the property of RTD EMBEDDED TECHNOLOGIES. Before returning any product for repair, customers are required to contact the factory for an RMA number.

THIS LIMITED WARRANTY DOES NOT EXTEND TO ANY PRODUCTS WHICH HAVE BEEN DAMAGED AS A RESULT OF ACCIDENT, MISUSE, ABUSE (such as: use of incorrect input voltages, improper or insufficient ventilation, failure to follow the operating instructions that are provided by RTD EMBEDDED TECHNOLOGIES, "acts of God" or other contingencies beyond the control of RTD EMBEDDED TECHNOLOGIES), OR AS A RESULT OF SERVICE OR MODIFICATION BY ANYONE OTHER THAN RTD EMBEDDED TECHNOLOGIES. EXCEPT AS EXPRESSLY SET FORTH ABOVE, NO OTHER WARRANTIES ARE EXPRESSED OR IMPLIED, INCLUDING, BUT NOT LIMITED TO, ANY IMPLIED WARRANTIES OF MERCHANTABILITY AND FITNESS FOR A PARTICULAR PURPOSE, AND RTD EMBEDDED TECHNOLOGIES EXPRESSLY DISCLAIMS ALL WARRANTIES NOT STATED HEREIN. ALL IMPLIED WARRANTIES, INCLUDING IMPLIED WARRANTIES FOR MERCHANTABILITY AND FITNESS FOR A PARTICULAR PURPOSE, ARE LIMITED TO THE DURATION OF THIS WARRANTY. IN THE EVENT THE PRODUCT IS NOT FREE FROM DEFECTS AS WARRANTED ABOVE, THE PURCHASER'S SOLE REMEDY SHALL BE REPAIR OR REPLACEMENT AS PROVIDED ABOVE. UNDER NO CIRCUMSTANCES WILL RTD EMBEDDED TECHNOLOGIES BE LIABLE TO THE PURCHASER OR ANY USER FOR ANY DAMAGES, INCLUDING ANY INCIDENTAL OR CONSEQUENTIAL DAMAGES, EXPENSES, LOST PROFITS, LOST SAVINGS, OR OTHER DAMAGES ARISING OUT OF THE USE OR INABILITY TO USE THE PRODUCT.

SOME STATES DO NOT ALLOW THE EXCLUSION OR LIMITATION OF INCIDENTAL OR CONSEQUENTIAL DAMAGES FOR CONSUMER PRODUCTS AND SOME STATES DO NOT ALLOW LIMITATIONS ON HOW LONG AN IMPLIED WARRANTY LASTS, SO THE ABOVE LIMITATIONS OR EXCLUSIONS MAY NOT APPLY TO YOU.

THIS WARRANTY GIVES YOU SPECIFIC LEGAL RIGHTS, AND YOU MAY ALSO HAVE OTHER RIGHTS WHICH VARY FROM STATE TO STATE.