

DM5814/DM6814 User's Manual

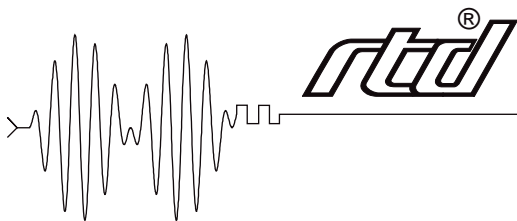

Real Time Devices USA, Inc.

"Accessing the Analog World"®

Publication No. 5814-04/24/98

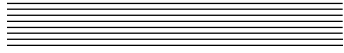

DM5814/DM6814 **User's Manual**



REAL TIME DEVICES USA, INC.

Post Office Box 906

State College, Pennsylvania 16804 USA

Phone: (814) 234-8087

FAX: (814) 234-5218

Published by
Real Time Devices USA, Inc.
P.O. Box 906
State College, PA 16804 USA

Copyright © 1998 by Real Time Devices USA, Inc.
All rights reserved

Printed in U.S.A.

Table of Contents

INTRODUCTION	<i>i-1</i>
Incremental Encoders	<i>i-3</i>
8254 Timer/Counters	<i>i-3</i>
What Comes With Your Module	<i>i-3</i>
Module Accessories	<i>i-3</i>
Application Software and Drivers	<i>i-3</i>
Hardware Accessories	<i>i-4</i>
Using This Manual	<i>i-4</i>
When You Need Help	<i>i-4</i>
CHAPTER 1 — MODULE SETTINGS	1-1
Factory-Configured Switch and Jumper Settings	1-3
P4 — Interrupt Channel Select (Factory Setting: Jumper installed on G; IRQ Disabled)	1-4
P5 — 8254 Clock and Gate Source Select (Factory Settings: See Figure 1-4)	1-6
P13 — Not Used	1-7
P14 — Interrupt Source Select (Factory Setting: OT2)	1-7
S1 — Base Address (Factory Setting: 300 hex (768 decimal))	1-8
P7 through P12, Pull-up/Pull-down Resistors on Digital I/O Lines	1-9
CHAPTER 2 — MODULE INSTALLATION	2-1
Module Installation	2-3
External I/O Connections	2-3
Connecting the Digital I/O	2-4
Connecting the Timer/Counter I/O	2-4
Connecting the External Interrupt	2-4
Running the 5814DIAG Diagnostics Program	2-4
CHAPTER 3 — HARDWARE DESCRIPTION	3-1
Incremental Encoders	3-3
Timer/Counters	3-3
CHAPTER 4 — I/O MAPPING	4-1
Defining the I/O Map	4-3
BA + 0: Incremental Encoder 1 MSB (Read/Write)	4-4
BA + 1: Incremental Encoder 1 MSB (Read/Write)	4-4
BA + 2: Incremental Encoder 1 Clear/Hold/Digital I/O (Read/Write)	4-4
BA + 3: Incremental Encoder 1 Chip Mode Register (Read/Write)	4-5
BA + 4: Incremental Encoder 2 MSB (Read/Write)	4-6
BA + 5: Incremental Encoder 2 MSB (Read/Write)	4-6
BA + 6: Incremental Encoder 2 Clear/Hold/Digital I/O (Read/Write)	4-6
BA + 7: Incremental Encoder 2 Chip Mode Register (Read/Write)	4-7
BA + 8: Incremental Encoder 3 MSB (Read/Write)	4-8
BA + 9: Incremental Encoder 3 MSB (Read/Write)	4-8
BA + 10: Incremental Encoder 3 Clear/Hold/Digital I/O (Read/Write)	4-8
BA + 11: Incremental Encoder 3 Chip Mode Register (Read/Write)	4-9
BA + 12: 8254 Timer/Counter 0 (Read/Write)	4-10
BA + 13: 8254 Timer/Counter 1 (Read/Write)	4-10

BA + 14: 8254 Timer/Counter 2 (Read/Write)	4-10
BA + 15: 8254 Timer/Counter Control Word (Write Only)	4-10
BA + 16: Clear IRQ/IRQ Enable (Read/Write)	4-10
BA + 17: IRQ Status (Read Only)	4-11
BA + 18: Reserved	4-11
BA + 19: Reserved	4-11
Programming the DM5814	4-12
Clearing and Setting Bits in a Port	4-12
CHAPTER 5 — DIGITAL I/O	5-1
CHAPTER 6 — TIMER/COUNTERS	6-1
CHAPTER 7 — INTERRUPTS	7-1
P14: Jumper Selectable Interrupts	7-3
Selecting the Interrupt Channel	7-3
Basic Programming For Interrupt Handling	7-4
What Is an Interrupt?	7-4
Interrupt Request Lines	7-4
8259 Programmable Interrupt Controller	7-4
Interrupt Mask Register (IMR)	7-4
End-of-Interrupt (EOI) Command	7-4
What Exactly Happens When an Interrupt Occurs?	7-5
Using Interrupts in Your Programs	7-5
Writing an Interrupt Service Routine (ISR)	7-5
Saving the Startup Interrupt Mask Register (IMR) and Interrupt Vector	7-6
Restoring the Startup IMR and Interrupt Vector	7-7
Common Interrupt Mistakes	7-7
APPENDIX A — DM5814/DM6814 SPECIFICATIONS	A-1
APPENDIX B — CONNECTOR PIN ASSIGNMENTS	B-1
APPENDIX C — COMPONENT DATA SHEETS	C-1
APPENDIX D — OPTIONAL DM5814 CONFIGURATIONS	D-1
Mixing Incremental Encoder Chips and Digital I/O Circuits on the Same Module	D-3
I/O Mapping for 16 Bit Programmable I/O Lines	D-3
I/O Mapping for 16 Bit Programmable I/O Lines	D-6
Digital Interrupts	D-9
Advanced Digital Interrupts - 8 Bit Programmable/8 Byte Programmable Only	D-9
Sampling Digital Lines for Change of State	D-10
Selecting the Interrupt Channel	D-10
Resetting the Digital Circuitry	D-10
Strobing Data into Ports 0/1, 2/3, and 4/5	D-10
APPENDIX E — WARRANTY	E-1

List of Illustrations

1-1	Module Layout Showing Factory-Configured Settings	1-4
1-2	Interrupt Channel Select Jumper, P4	1-5
1-3	Pulling Down the Interrupt Request Lines	1-5
1-4	8254 Clock and Gate Sources Jumpers, P5	1-6
1-5	8254 Circuit Diagram	1-6
1-6	Interrupt Source Select Jumper, P14	1-7
1-7	Base Address Switch, S1	1-8
1-8	Port 0 Pull-up/Pull-down Resistor Connections, P7	1-9
2-1	P2, P3, and P6 I/O Connector Pin Assignments	2-4
3-1	DM5814 Block Diagram	3-3
3-2	Timer/Counter Circuit Block Diagram	3-4
6-1	8254 Timer/Counter Circuit Block Diagram	6-3
D-1	Digital Interrupt Timing Diagram	D-10

INTRODUCTION

The DM5814/DM6814 incremental encoder dataModule® turns your IBM PC-compatible cpuModule™ or other PC/104 computer into a high-performance control system. The DM5814 and DM6814 are the same board except for the addition of the AT bus connector on the DM6814. This connector allows you to stack the module easily with other AT modules and also allows you access to the AT interrupts. Through the rest of this manual, the module will be referred to as the DM5814. Ultra-compact for embedded and portable applications, the module features:

- Three 16-bit incremental encoder up/down counters,
- Three 16-bit timer/counters and on-board 8 MHz clock,
- Direct connection to opto-22 I/O system modules,
- Operation from single +5V supply,
- DOS example programs with source code in BASIC and C,
- Diagnostics software.

The following paragraphs briefly describe the major functions of the module. A detailed discussion of module functions is included in subsequent chapters.

Incremental Encoders

Depending on your specifications when ordering your DM5814, your module will have up to three incremental encoder circuits. Each of these circuits has one 16-bit up/down counter for incremental encoding applications such as position encoding and velocity detection, and eight digital I/O lines available for control functions. Six lines are input only, and two are input/output.

The body of this manual is written for a DM5814 configured with three incremental encoder circuits on board. Your module can have one, two, or three such circuits, depending on your specifications to the factory at the time of your order. If you have less than three encoder circuits, the remaining circuits each consist of 16 programmable digital I/O lines. Appendix D will help you understand how to program your module if you have a DM5814 that combines incremental encoder and digital I/O circuits on the same module.

8254 Timer/Counters

An 8254 programmable interval timer provides three 16-bit, 8 MHz timer/counters to support a wide range of user timing and counting functions.

What Comes With Your Module

You receive the following items in your module package:

- DM5814 module with stackthrough bus header
- Mounting hardware
- Example programs in BASIC and C with source code & diagnostics software
- User's manual

If any item is missing or damaged, please call Real Time Devices' Customer Service Department at (814) 234-8087. If you require service outside the U.S., contact your local distributor.

Module Accessories

In addition to the items included in your module package, Real Time Devices offers a full line of software and hardware accessories. Call your local distributor or our main office for more information about these accessories and for help in choosing the best items to support your module's application.

Hardware Accessories

Hardware accessories for the DM5814 include the DOP series opto-22 optoisolated digital input boards, the DMR series opto-22 mechanical relay output boards, the TB50 terminal board and XB50 prototype/terminal board for easy signal access and prototype development, the DM14 extender board for testing your module in a conventional desktop computer, and XT50 twisted pair wire flat ribbon cable assembly for external interfacing.

Using This Manual

This manual is intended to help you install your new module and get it running quickly, while also providing enough detail about the module and its functions so that you can enjoy maximum use of its features even in the most complex applications. We assume that you already have an understanding of data acquisition principles and that you can customize the example software or write your own application programs.

When You Need Help

This manual and the example programs in the software package included with your module provide enough information to properly use all of the module's features. If you have any problems installing or using this dataModule, contact our Technical Support Department, (814) 234-8087, during regular business hours, eastern standard time or eastern daylight time, or send a FAX requesting assistance to (814) 234-5218. When sending a FAX request, please include your company's name and address, your name, your telephone number, and a brief description of the problem. You can also contact us through our E-mail address **techsupport@rtdusa.com**.

CHAPTER 1

MODULE SETTINGS

The DM5814 has jumper and switch settings you can change if necessary for your application. The module is factory-configured as listed in the table and shown on the layout diagram in the beginning of this chapter. Should you need to change these settings, use these easy-to-follow instructions before you stack the module with your computer system.

Also note that by setting the jumpers as desired on header connectors P7 through P12 for digital I/O lines on the module, you can configure each digital I/O line to be pulled up or pulled down. This procedure is explained at the end of this chapter.

Factory-Configured Switch and Jumper Settings

Table 1-1 lists the factory settings of the user-configurable jumpers and switch on the DM5814 module. Figure 1-1 shows the module layout and the locations of the factory-set jumpers. The following paragraphs explain how to change the factory settings. Pay special attention to the setting of S1, the base address switch, to avoid address contention when you first use your module in your system.

Table 1-1 Factory Settings		
Switch/ Jumper	Function Controlled	Factory Settings (Jumpers Installed)
P4	Connects a P14 jumper selectable interrupt source to an interrupt channel; pulls tri-state buffers to ground (G) for multiple interrupt applications	Jumper installed on G (ground for buffer); interrupt channels disabled
P5	Sets the clock and gate sources for the 8254 timer/counter	CLK0: OSC; CLK1: OT0 CLK2:OT1; GT2:EG2 (timer/counters cascaded)
P7	Activates pull-up/ pull-down resistors on Port 0 digital I/O lines (Port 0, lines 0-3 only)	Not Installed
P8	Activates pull-up/ pull-down resistors on Port 1 digital I/O lines (Port 1, lines 0-3 only)	Not Installed
P9	Activates pull-up/ pull-down resistors on Port 2 digital I/O lines (Port 2, lines 0-3 only)	Not Installed
P10	Activates pull-up/ pull-down resistors on Port 3 digital I/O lines (Port 3, lines 0-3 only)	Not Installed
P11	Activates pull-up/ pull-down resistors on Port 4 digital I/O lines (Port 4, lines 0-3 only)	Not Installed
P12	Activates pull-up/ pull-down resistors on Port 5 digital I/O lines (Port 5, lines 0-3 only)	Not Installed
P13	Not used	No Connection
P14	Selects one of four interrupt sources for interrupt generation	OT2
P16	Connects interrupt source jumpered on P14 to an AT interrupt channel (DM6814 only)	no jumper
S1	Sets the base address	300 hex (768 decimal)

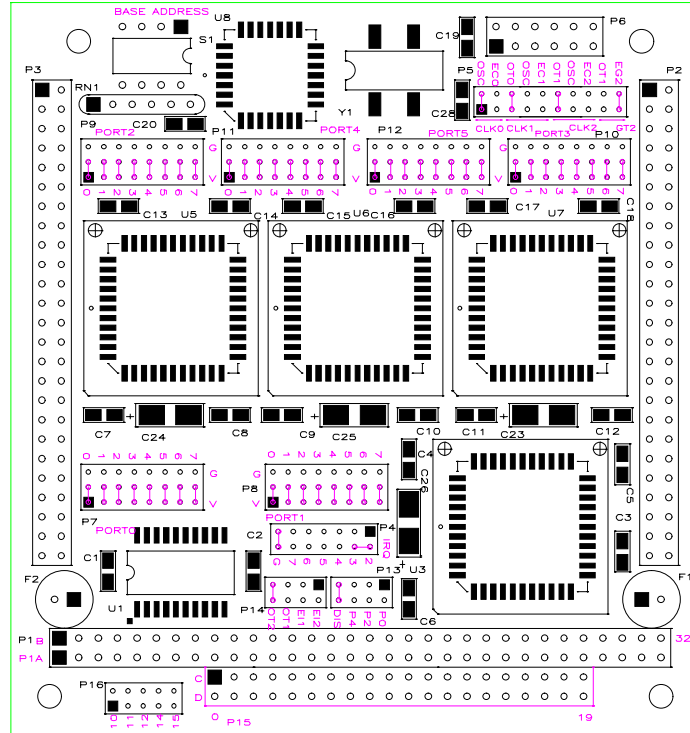

Fig. 1-1 — Module Layout Showing Factory-Configured Settings

P4, P16 — Interrupt Channel Select (Factory Setting: Jumper installed on G; IRQ Disabled)

These header connectors, shown in Figure 1-2, lets you connect any one of four jumper selectable (P14) interrupt sources or any of the 16 digital I/O lines in each EPLD (up to three digital interrupt sources) to an interrupt channel, IRQ2 through IRQ15. XT channels 2 through 7 are jumpered on P4 and AT channels 10 through 15 are jumpered on P16 (DM6814 only). In AT computers channels 2 and 9 are the same channel. To activate a channel, you must install a jumper vertically across the desired IRQ channel's pins. Only one channel on either P4 or P16 should be jumpered at any time. Figure 1-2a shows the factory settings.

This module supports an interrupt sharing mode where the pins labeled G connect a 1 kilohm pull-down resistor to the output of a high-impedance tri-state driver which carries the interrupt request signal. This pull-down resistor drives the interrupt request line low whenever interrupts are not active. Whenever an interrupt request is made, the tri-state buffer is enabled, forcing the output high and generating an interrupt. There are four IRQ circuits, one for the P14 jumper selectable interrupts and one each for the incremental encoder channels. Their outputs are tied together through an "OR" gate, allowing all interrupt sources to share the same IRQ channel. To determine which circuit has generated an interrupt on the selected IRQ channel, read the status byte (I/O address location BA + 17) and check the status of bits 0 through 3, as described in Chapter 4. After the interrupt has been serviced, you must return the IRQ line low, disabling the tri-state buffer and pulling the output low again. This is done by clearing the IRQ for the source which generated the interrupt. You also can have two or more modules that share the same IRQ channel. You can tell which module issued the interrupt request by monitoring each module's IRQ status bit(s). If you are not planning on sharing interrupts or if you are not sure that your CPU supports interrupt sharing, it is best to disable this feature and use the interrupts in the normal mode. This will insure compatibility with all CPUs. See chapter 4 for details on disabling the interrupt sharing circuit.

NOTE: When using multiple modules sharing the same interrupt, only one module should have the G jumper installed. The rest should be disconnected. Whenever you operate a single module, the G jumper should be installed. Whenever you operate the module with interrupt sharing disabled, the G jumper should be removed.

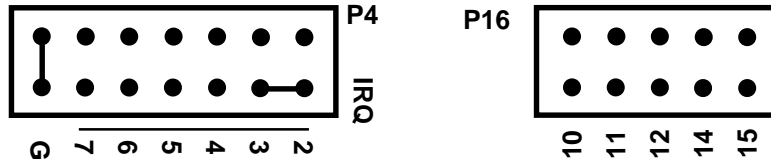

Fig. 1-2 — Interrupt Channel Select Jumpers, P4 and P16

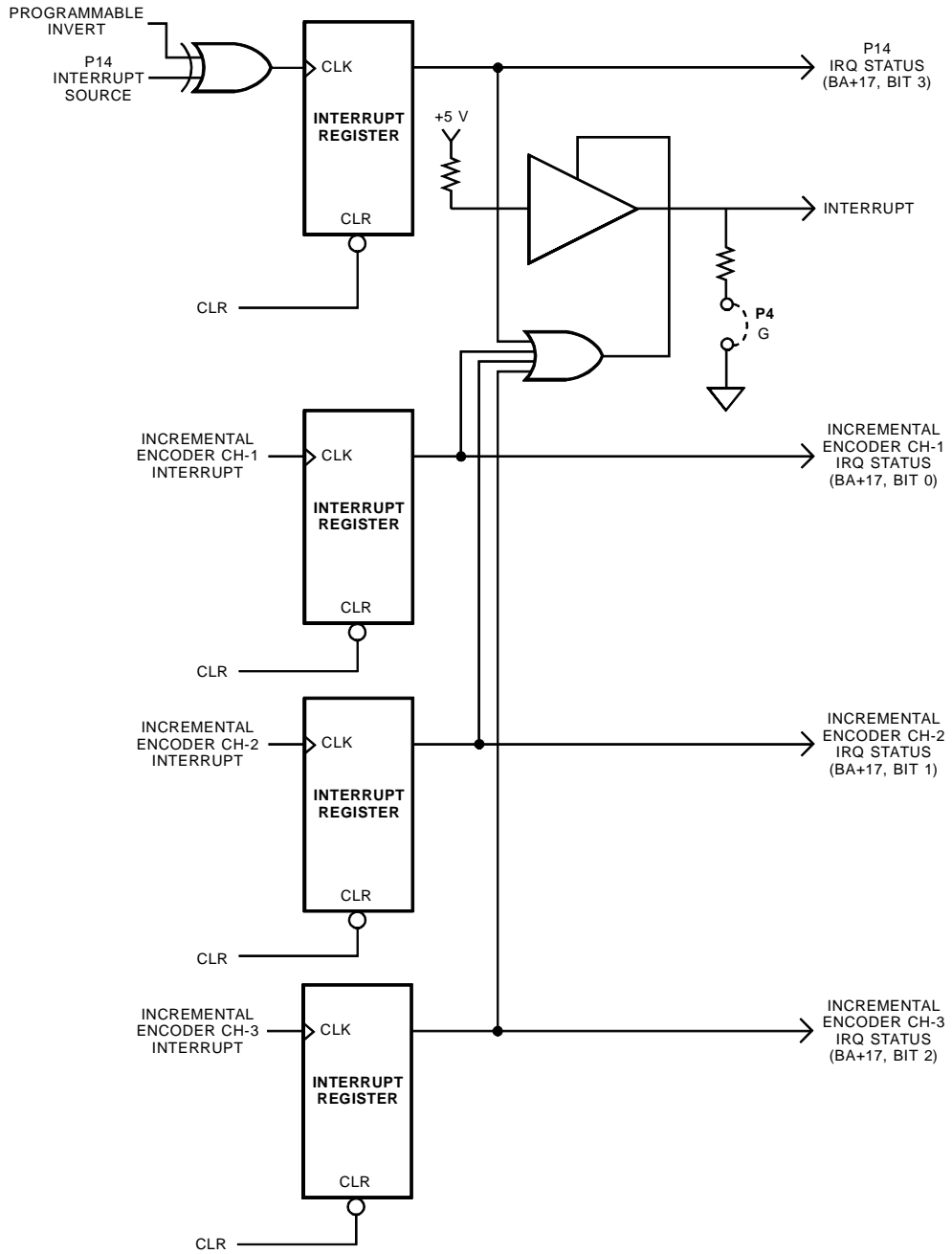

Fig. 1-3 — Pulling Down the Interrupt Request Lines

P5 — 8254 Clock and Gate Source Select (Factory Settings: See Figure 1-4)

This header connector, shown in Figure 1-4, lets you select the clock sources for the three 8254 16-bit timer/counters. Figure 1-5 shows a block diagram of the timer/counter circuitry to help you in making these connections.

The clock source for Counter 0 is selected by placing a jumper on one of the two leftmost pairs of pins on the header, OSC or EC0. OSC is the on-board 8 MHz clock, and EC0 is an external clock source which can be connected through I/O connector P6, pin 1. Counter 1 has three clock sources: OT0, which cascades it to Counter 0; OSC, which is the on-board 8 MHz clock; and EC1, which is an external clock source connected through I/O connector P6, pin 5. Counter 2 has three clock sources: OT1, which cascades it to Counter 1; OSC, which is the on-board 8 MHz clock; and EC2, which is an external clock source connected through I/O connector P6, pin 9.

The gate of Counter 2 can be connected to the output of Counter 1 (OT1) or to an external gate source (EG2) connected through I/O connector P6, pin 10. When no external gate source is connected, this line is tied high.

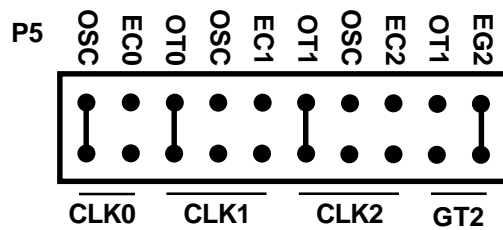

Fig. 1-4 — 8254 Clock and Gate Sources Jumpers, P5

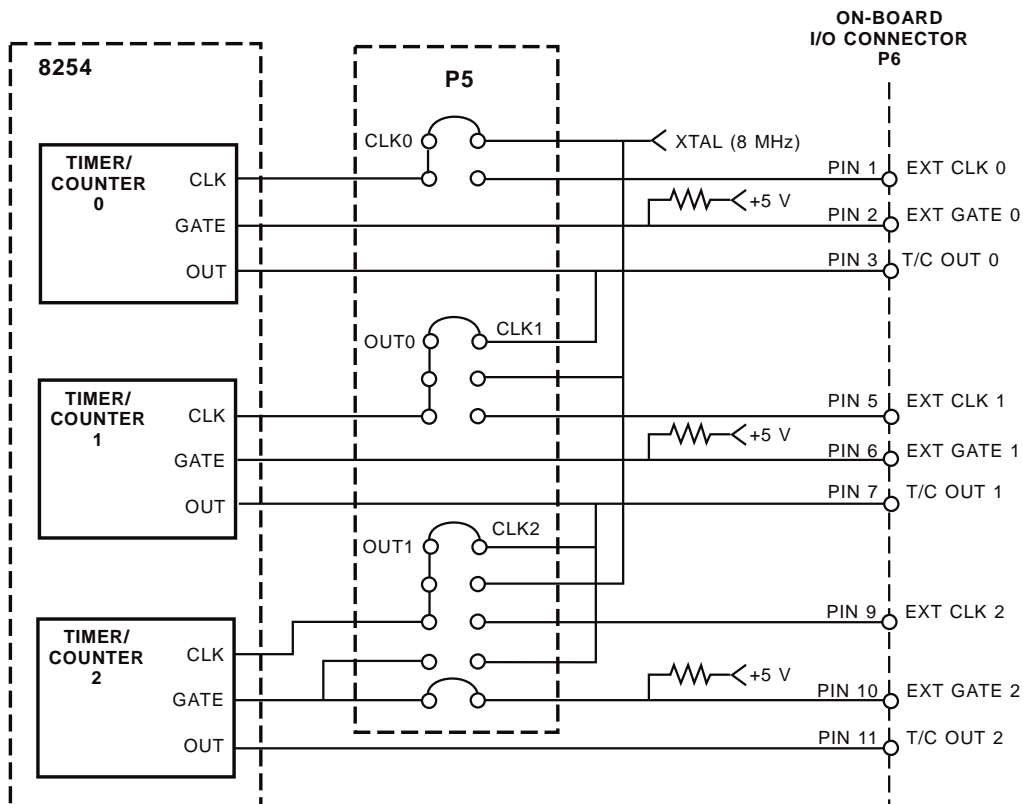

Fig. 1-5 — 8254 Circuit Diagram

P13 — Not Used

This header connector is not used on the DM5814 and should have no jumpers installed.

P14 — Interrupt Source Select (Factory Setting: OT2)

This header connector, shown in Figure 1-6, lets you select one of four interrupt sources for interrupt generation. The four sources are: EI1, external interrupt 1, P2-2); EI2, external interrupt 2, P3-2); OT1, the output of timer/counter 1; and OT2, the output of timer/counter 2. To connect an interrupt source, place the jumper across the desired set of pins.

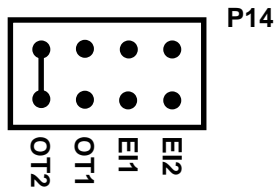

Fig. 1-6 — Interrupt Source Select Jumper, P14

S1 — Base Address (Factory Setting: 300 hex (768 decimal))

One of the most common causes of failure when you are first trying your module is address contention. Some of your computer's I/O space is already occupied by internal I/O and other peripherals. When the module attempts to use I/O address locations already used by another device, contention results and the module does not work.

To avoid this problem, the DM5814 has an easily accessible DIP switch, S1, which lets you select any one of 16 starting addresses in the computer's I/O. Should the factory setting of 300 hex (768 decimal) be unsuitable for your system, you can select a different base address simply by setting the switches to any one of the values listed in Table 1-2. The table shows the switch settings and their corresponding decimal and hexadecimal (in parentheses) values. Make sure that you verify the order of the switch numbers on the switch (1 through 4) before setting them. When the switches are pulled forward, they are OPEN, or set to logic 1, as labeled on the DIP switch package. When you set the base address for your module, record the value in the table inside the back cover. Figure 1-7 shows the DIP switch set for a base address of 300 hex (768 decimal).

Table 1-2 Base Address Switch Settings, S1			
Base Address Decimal / (Hex)	Switch Setting 4 3 2 1	Base Address Decimal / (Hex)	Switch Setting 4 3 2 1
512 / (200)	0 0 0 0	768 / (300)	1 0 0 0
544 / (220)	0 0 0 1	800 / (320)	1 0 0 1
576 / (240)	0 0 1 0	832 / (340)	1 0 1 0
608 / (260)	0 0 1 1	864 / (360)	1 0 1 1
640 / (280)	0 1 0 0	896 / (380)	1 1 0 0
672 / (2A0)	0 1 0 1	928 / (3A0)	1 1 0 1
704 / (2C0)	0 1 1 0	960 / (3C0)	1 1 1 0
736 / (2E0)	0 1 1 1	992 / (3E0)	1 1 1 1

0 = Closed, 1 = Open

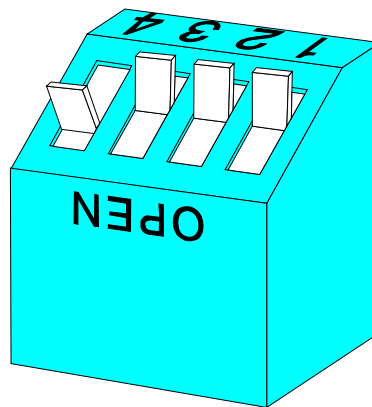

Fig. 1-7 — Base Address Switch, S1

P7 through P12, Pull-up/Pull-down Resistors on Digital I/O Lines

The DM5814 has 24 TTL/CMOS compatible digital I/O lines which can be interfaced with external devices. These lines are grouped into eight lines each per encoder circuit. Six lines are input only and two are I/O lines. You can connect pull-up or pull-down resistors to any or all of these lines on a bit by bit basis. You may want to pull lines up for connection to switches. This will pull the line high when the switch is disconnected. Or, you may want to pull lines down for connection to relays which control turning motors on and off. These motors turn on when the digital lines controlling them are high. By pulling these lines down, you can ensure that when the data acquisition system is first turned on, the motors will not switch on before the port is initialized.

Pull-up/pull-down resistors have been factory installed on the module, and jumpers have been provided for P7 through P12, bits 0 through 3, for all 24 digital lines. Bits 4 through 7 on all six connectors are not used and should not be jumpered. Each port and bit is labeled on the module. P7 connects to the resistors for Port 0 (P0.0-P0.3), P8 connects to the resistors for Port 1 (P1.0-P1.3), and so on. The pins are labeled G (for ground) on one end and V (for +5V) on the other end. The middle pin is common. Figure 1-8 shows P7 with the factory-installed jumpers placed between the common pin (middle pin of the three) and the V pin. For pull-downs, install the jumper across the common pin (middle pin) and G pin. To disable the pull-up/pull-down resistor, remove the jumper.

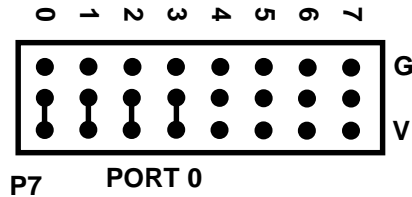

Fig. 1-8 — Port 0 Pull-up/Pull-down Resistor Connections, P7

CHAPTER 2

MODULE INSTALLATION

The DM5814 is easy to install in your cpuModule™ or other PC/104 based system. This chapter tells you step-by-step how to install and connect the module.

After you have installed the module and made all of your connections, you can turn your system on and run the 5814DIAG board diagnostics program included on your example software disk to verify that your module is working.

Module Installation

Keep the module in its antistatic bag until you are ready to install it in your cpuModule™ or other PC/104 based system. When removing it from the bag, hold the module at the edges and do not touch the components or connectors.

Before installing the module in your system, check the jumper and switch settings. Chapter 1 reviews the factory settings and how to change them. If you need to change any settings, refer to the appropriate instructions in Chapter 1. Note that incompatible jumper settings can result in unpredictable module operation and erratic response.

The DM5814 comes with a stackthrough P1 connector. The stackthrough connector lets you stack another module on top of your DM5814.

To install the module, follow the procedures described in the computer manual and the steps below:

1. Turn OFF the power to your system.
2. Touch a metal rack to discharge any static buildup and then remove the module from its antistatic bag.
3. Select the appropriate standoffs for your application to secure the module when you install it in your system (two sizes are included with the module).
4. Holding the module by its edges, orient it so that the P1 bus connector's pin 1 lines up with pin 1 of the expansion connector onto which you are installing the module.
5. After carefully positioning the module so that the pins are lined up and resting on the expansion connector, gently and evenly press down on the module until it is secured on the connector.

NOTE: Do not force the module onto the connector. If the module does not readily press into place, remove it and try again. Wiggling the module or exerting too much pressure can result in damage to the DM5814 or to the mating module.

6. After the module is installed, connect the cables as needed to I/O connector P2, P3, and P6 on the module. When making these connection, note that there is no keying to guide you in orientation. You must make sure that pin 1 of the cable is connected to pin 1 of the connector (pin 1 is marked on the module with a small square). For twisted pair cables, pin 1 is the dark brown wire; for standard single wire cables, pin 1 is the red wire.
7. Make sure all connections are secure.

External I/O Connections

Figure 2-1 shows I/O connector pinouts for P2, P3, and P6. Refer to these diagrams as you make your I/O connections.

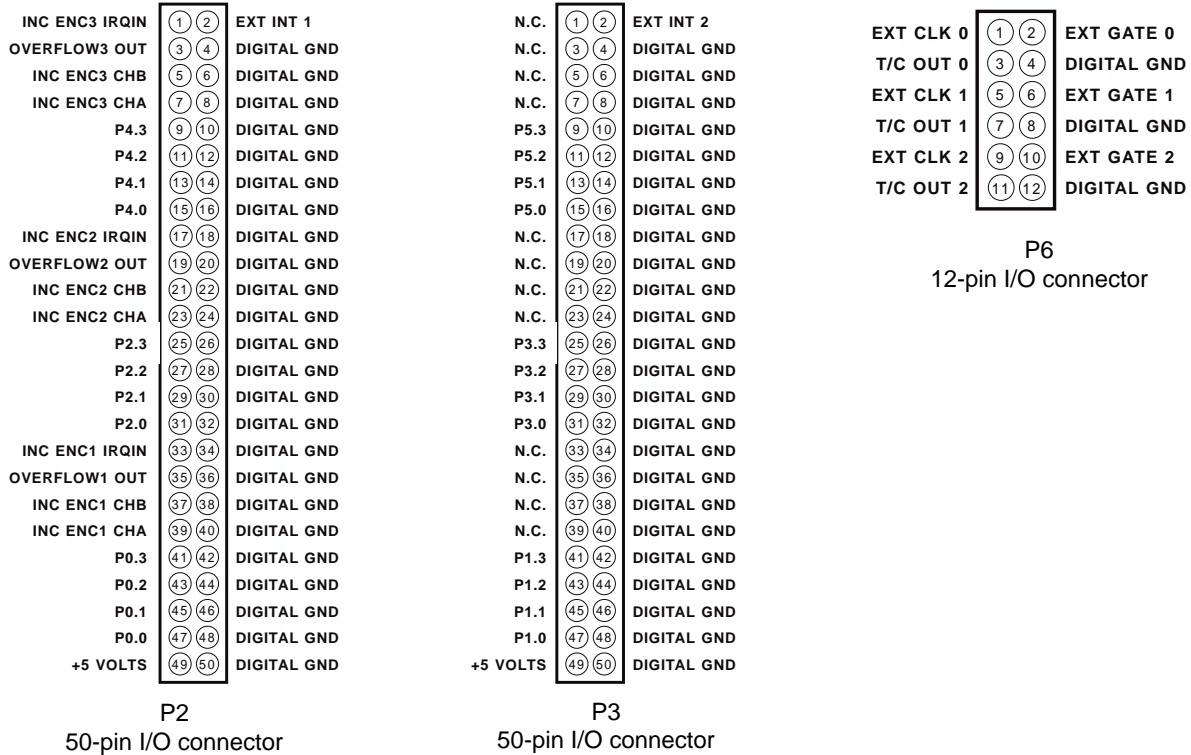

Fig. 2-1 — P2, P3, and P6 I/O Connector Pin Assignments

Connecting the Digital I/O

The DM5814 is designed for direct connection to industry standard opto-22 isolated I/O racks and system modules. Each digital I/O line has a digital ground, as shown in Figure 2-1. For all digital I/O connections, the high side of an external signal source or destination device is connected to the appropriate signal pin on the I/O connector, and the low side is connected to the DIGITAL GND. A cable to provide direct connection to opto-22 systems, the XO50, is available as an accessory from RTD.

Connecting the Timer/Counter I/O

External connections to the timer/counters on the DM5812 can be made by connecting the high side of the external device to the appropriate signal pin on I/O connector P6 and the low side to a P6 DIGITAL GND.

Connecting the External Interrupt

The DM5814 can receive externally generated interrupt signals – EXT INT1, through I/O connector P2, pin 2, and EXT INT2, through I/O connector P3, pin 2 – and route them to an IRQ channel through on-board header connectors P14 and P4. Interrupt generation is enabled through software. When interrupts are enabled, a rising or falling edge on the EXT INT line will cause the selected IRQ line to go high, depending on the setting of BA + 16, bit 1, and the IRQ status bit will change from 0 to 1. The pulse applied to the EXT INT pin should have a duration of at least 100 nanoseconds.

Running the 5814DIAG Diagnostics Program

Now that your module is ready to use, you will want to try it out. An easy-to-use, menu-driven diagnostics program, 5814DIAG, is included with your example software to help you verify your module’s operation. You can also use this program to make sure that your current base address setting does not contend with another device.

CHAPTER 3

HARDWARE DESCRIPTION

This chapter describes the features of the DM5814 hardware. The major circuits are the incremental encoders and the timer/counters.

The DM5814 has two major circuits, the incremental encoders and the timer/counters. Figure 3-1 shows the block diagram of the module. This chapter describes the hardware which makes up the the major circuits.

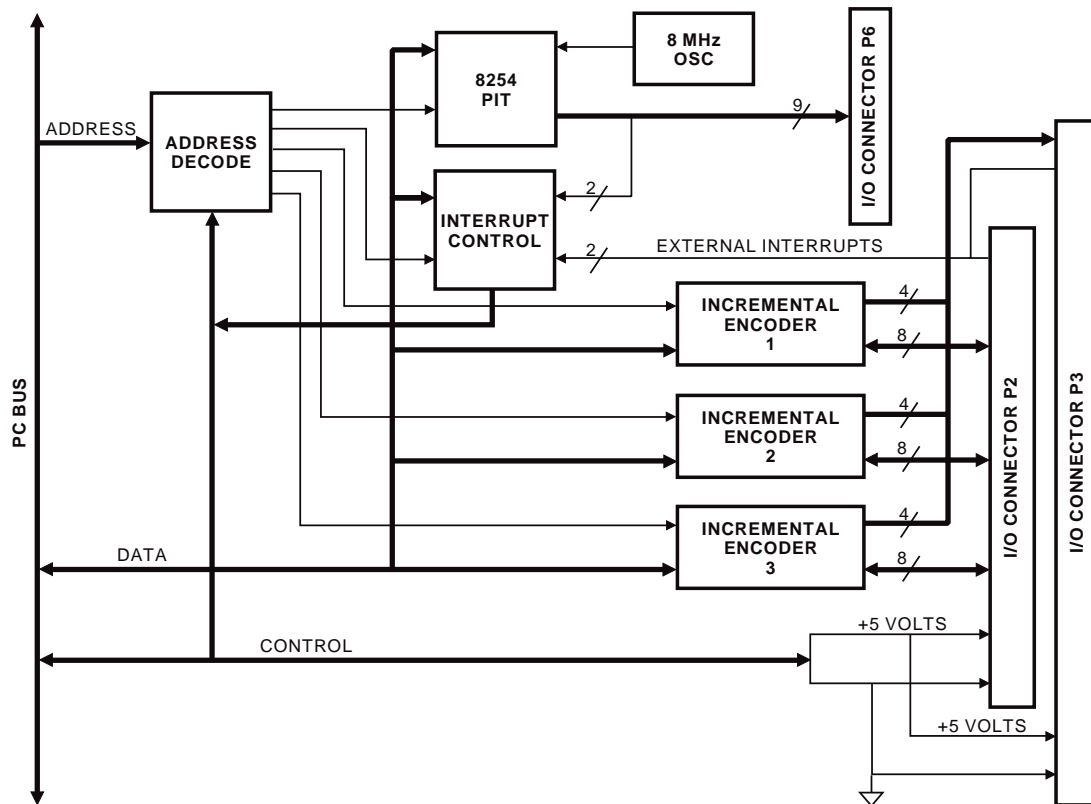

Fig. 3-1 — DM5814 Block Diagram

Incremental Encoders

The DM5814 has three incremental encoder circuits. Each circuit has one 16-bit up/down counter for incremental encoding applications such as position encoding and velocity detection, and eight digital I/O lines available for control functions. Six lines are input only and two lines are input/output (see I/O connector pinout diagrams in Appendix B).

Timer/Counters

An 8254 programmable interval timer provides three 16-bit, 8-MHz timer/counters to support a wide range of timing and counting functions. Figure 3-2 shows the timer/counter circuitry.

Each 16-bit timer/counter has two inputs, CLK in and GATE in, and one output, timer/counter OUT. Each can be programmed as binary or BCD down counters by writing the appropriate data to the command word, as described in Chapter 4. The command word also lets you set up the mode of operation. The six programmable modes are:

- Mode 0 Event Counter (Interrupt on Terminal Count)
- Mode 1 Hardware-Retriggerable One-Shot
- Mode 2 Rate Generator
- Mode 3 Square Wave Mode
- Mode 4 Software-Triggered Strobe
- Mode 5 Hardware Triggered Strobe (Retriggerable)

These modes are detailed in the 8254 Data Sheet, reprinted from Intel in Appendix C.

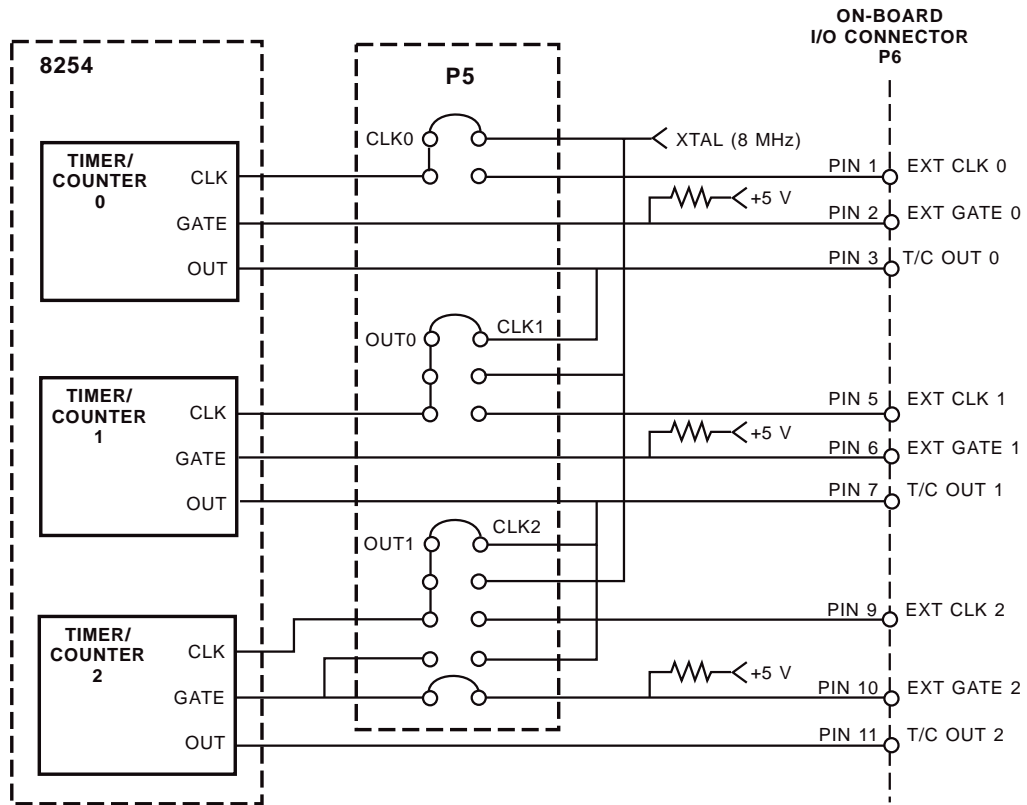

Fig. 3-2 — Timer/Counter Circuit Block Diagram

CHAPTER 4

I/O MAPPING

This chapter provides a complete description of the I/O map for the DM5814, general programming information, and how to set and clear bits in a port.

Defining the I/O Map

The I/O map for the DM5814 is shown in Table 4-1 below. As shown, the module occupies 20 consecutive I/O port locations.

The base address (designated as BA) can be selected using DIP switch S1, located on the edge of the module, as described in Chapter 1, *Module Settings*. This switch can be accessed without removing the module from the stack. The following sections describe the register contents of each address used in the I/O map.

Table 4-1 DM5814 I/O Map			
Register Description	Read Function	Write Function	Address * (Decimal)
Incremental Encoder 1 LSB	Read bottom 8 bits of up/down counter	Program starting value into bottom 8 bits of up/down counter	BA + 0
Incremental Encoder 1 MSB	Read top 8 bits of up/down counter	Program starting value into top 8 bits of up/down counter	BA + 1
Incremental Encoder 1 Clear/Hold/Digital I/O	Clear IRQ status flag/read 8 digital input lines (dependent on BA + 3)	Clear chip/latch counter value/program 2 digital output lines (dependent on BA + 3)	BA + 2
Incremental Encoder 1 Chip Mode Register	Read Incremental Encoder 1 control register	Program Incremental Encoder 1 control register	BA + 3
Incremental Encoder 2 LSB	Read bottom 8 bits of up/down counter	Program starting value into bottom 8 bits of up/down counter	BA + 4
Incremental Encoder 2 MSB	Read top 8 bits of up/down counter	Program starting value into top 8 bits of up/down counter	BA + 5
Incremental Encoder 2 Clear/Hold/Digital I/O	Clear IRQ status flag/read 8 digital input lines (dependent on BA + 7)	Clear chip/latch counter value/program 2 digital output lines (dependent on BA + 7)	BA + 6
Incremental Encoder 2 Chip Mode Register	Read Incremental Encoder 2 control register	Program Incremental Encoder 2 control register	BA + 7
Incremental Encoder 3 LSB	Read bottom 8 bits of up/down counter	Program starting value into bottom 8 bits of up/down counter	BA + 8
Incremental Encoder 3 MSB	Read top 8 bits of up/down counter	Program starting value into top 8 bits of up/down counter	BA + 9
Incremental Encoder 3 Clear/Hold/Digital I/O	Clear IRQ status flag/read 8 digital input lines (dependent on BA + 11)	Clear chip/latch counter value/program 2 digital output lines (dependent on BA + 11)	BA + 10
Incremental Encoder 3 Chip Mode Register	Read Incremental Encoder 3 control register	Program Incremental Encoder 3 control register	BA + 11
8254 TC Counter 0	Read value in Counter 0	Load count in Counter 0	BA + 12
8254 TC Counter 1	Read value in Counter 1	Load count in Counter 1	BA + 13
8254 TC Counter 2	Read value in Counter 2	Load count in Counter 2	BA + 14
8254 Control Word	Reserved	Program counter mode	BA + 15
Clear IRQ/IRQ Enable	Clear interrupt line (P14)	Enable interrupt line (P14), Disable interrupt sharing	BA + 16
IRQ Status	Read interrupt status	Reserved	BA + 17
Reserved	Reserved	Reserved	BA + 18
Reserved	Reserved	Reserved	BA + 19

* BA = Base Address

BA + 0: Incremental Encoder 1 MSB (Read/Write)

This port accesses the bottom eight bits of the Incremental Encoder 1 16-bit up/down counter. A read provides the current LSB value in the counter. A write loads the bottom eight bits of a starting value into the counter. When writing an initial value to the counter, you must first disable the Incremental Encoder input by setting BA + 3, bits 6 and 5 to 00.

Note that before doing a read of this register, you should first issue a hold command (at BA + 2) to ensure that you do not read the chip in the middle of a count. Also, when reading the count, be sure to read the LSB first, followed by the MSB.



BA + 1: Incremental Encoder 1 MSB (Read/Write)

This port accesses the top eight bits of the Incremental Encoder 1 16-bit up/down counter. A read provides the current MSB value in the counter. A write loads the top eight bits of a starting value into the counter. When writing an initial value to the counter, you must first disable the Incremental Encoder input by setting BA + 3, bits 6 and 5 to 00.

Note that before doing a read of this register, you should first issue a hold command (at BA + 2) to ensure that you do not read the chip in the middle of a count. Also, when reading the count, be sure to read the LSB first, followed by the MSB.

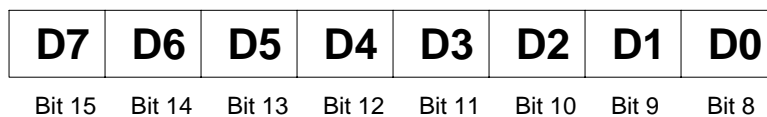

BA + 2: Incremental Encoder 1 Clear/Hold/Digital I/O (Read/Write)

This port controls three different functions of the Incremental Encoder 1 chip. The function performed at this address depends on the setting of bits 1 and 0 at BA + 3.

If BA + 3, bits 1 and 0 are 00, a read clears the Incremental Encoder 1 IRQ status flag, and a write at this address clears the chip. Clearing the IRQ status flag simply resets the flag to 0. Clearing the entire chip resets the IRQ status flag to 0, sets all digital I/O lines for input, and clears the contents of the 16-bit Incremental Encoder 1 counter.

If BA + 3, bits 1 and 0 are 01, a write at this address commands the Incremental Encoder 1 counter to latch its current count value in a hold register. A read is ignored.

If BA + 3, bits 1 and 0 are 10, a read at this address returns the value of the six digital input lines plus P0.0 and P0.1 if they are set up as digital input lines, and a write sends a value out to P0.0 and P0.1 if they are set up as digital output lines.

Digital I/O Register (BA + 3, bits 1 and 0 = 10):

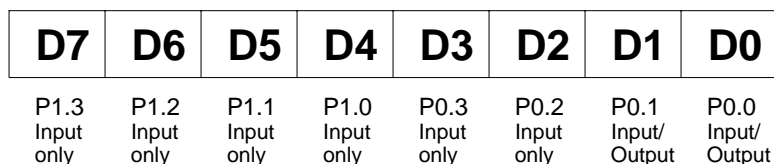

BA + 3: Incremental Encoder 1 Chip Mode Register (Read/Write)

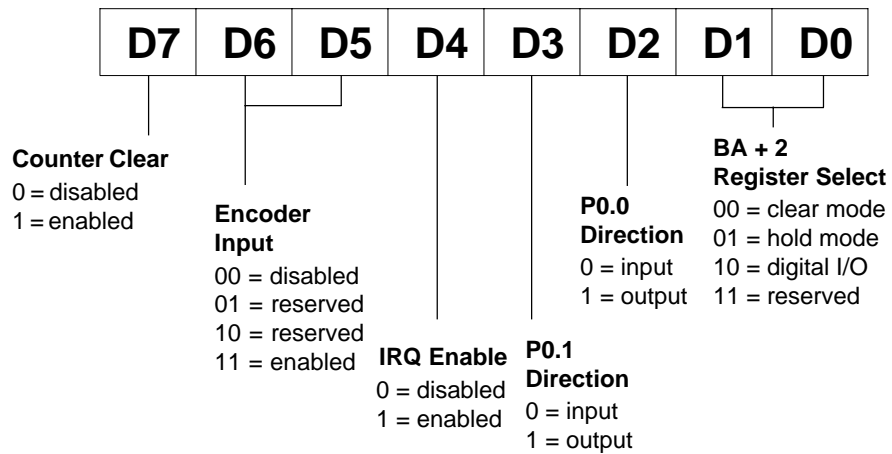

- Bits 0 and 1 – Select clear mode, hold mode, or digital I/O mode for operations performed at BA + 2.
- Bit 2 – Sets the direction of the P0.0 digital line.
- Bit 3 – Sets the direction of the P0.1 digital line.
- Bit 4 – Disables/enables the interrupt circuit on the Incremental Encoder 1 chip. The IRQ channel is determined by the jumper setting on P4.
- Bits 5 and 6 – Disables/enables the Incremental Encoder 1 input pulse.
- Bit 7 – This bit is used to enable digital input P0.2 as a signal that can be used to clear the incremental encoder counter. When this bit is high and the P0.2 input is held high, the counter is held in reset. When the P0.2 line is low, the counters count normally. If this bit is kept low, the P0.2 line has no affect on the counter. This function is normally connected to the index pulse from the incremental encoder.

A read returns the current settings of the bits.

BA + 4: Incremental Encoder 2 MSB (Read/Write)

This port accesses the bottom eight bits of the Incremental Encoder 2 16-bit up/down counter. A read provides the current LSB value in the counter. A write loads the bottom eight bits of a starting value into the counter. When writing an initial value to the counter, you must first disable the Incremental Encoder input by setting BA + 7, bits 6 and 5 to 00.

Note that before doing a read of this register, you should first issue a hold command (at BA + 6) to ensure that you do not read the chip in the middle of a count. Also, when reading the count, be sure to read the LSB first, followed by the MSB.

D7	D6	D5	D4	D3	D2	D1	D0
Bit 7	Bit 6	Bit 5	Bit 4	Bit 3	Bit 2	Bit 1	Bit 0

BA + 5: Incremental Encoder 2 MSB (Read/Write)

This port accesses the top eight bits of the Incremental Encoder 2 16-bit up/down counter. A read provides the current MSB value in the counter. A write loads the top eight bits of a starting value into the counter. When writing an initial value to the counter, you must first disable the Incremental Encoder input by setting BA + 7, bits 6 and 5 to 00.

Note that before doing a read of this register, you should first issue a hold command (at BA + 6) to ensure that you do not read the chip in the middle of a count. Also, when reading the count, be sure to read the LSB first, followed by the MSB.

D7	D6	D5	D4	D3	D2	D1	D0
Bit 15	Bit 14	Bit 13	Bit 12	Bit 11	Bit 10	Bit 9	Bit 8

BA + 6: Incremental Encoder 2 Clear/Hold/Digital I/O (Read/Write)

This port controls three different functions of the Incremental Encoder 2 chip. The function performed at this address depends on the setting of bits 1 and 0 at BA + 7.

If BA + 7, bits 1 and 0 are 00, a read clears the Incremental Encoder 2 IRQ status flag, and a write at this address clears the chip. Clearing the IRQ status flag simply resets the flag to 0. Clearing the entire chip resets the IRQ status flag to 0, sets all digital I/O lines for input, and clears the contents of the 16-bit Incremental Encoder 2 counter.

If BA + 7, bits 1 and 0 are 01, a write at this address commands the Incremental Encoder 1 counter to latch its current count value in a hold register. A read is ignored.

If BA + 7, bits 1 and 0 are 10, a read at this address returns the value of the six digital input lines plus P2.0 and P2.1 if they are set up as digital input lines, and a write sends a value out to P2.0 and P2.1 if they are set up as digital output lines.

Digital I/O Register (BA + 7, bits 1 and 0 = 10):

D7	D6	D5	D4	D3	D2	D1	D0
P3.3 Input only	P3.2 Input only	P3.1 Input only	P3.0 Input only	P2.3 Input only	P2.2 Input only	P2.1 Input/ Output	P2.0 Input/ Output

BA + 7: Incremental Encoder 2 Chip Mode Register (Read/Write)

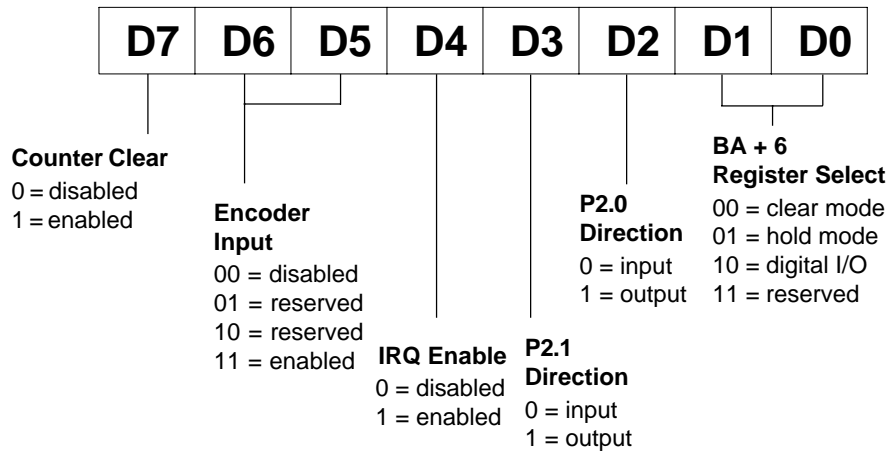

- Bits 0 and 1 – Select clear mode, hold mode, or digital I/O mode for operations performed at BA + 6.
- Bit 2 – Sets the direction of the P2.0 digital line.
- Bit 3 – Sets the direction of the P2.1 digital line.
- Bit 4 – Disables/enables the interrupt circuit on the Incremental Encoder 2 chip. The IRQ channel is determined by the jumper setting on P4.
- Bits 5 and 6 – Disables/enables the Incremental Encoder 2 input pulse.
- Bit 7 – This bit is used to enable digital input P2.2 as a signal that can be used to clear the incremental encoder counter. When this bit is high and the P2.2 input is held high, the counter is held in reset. When the P2.2 line is low, the counters count normally. If this bit is kept low, the P2.2 line has no affect on the counter. This function is normally connected to the index pulse from the incremental encoder.

A read returns the current settings of the bits.

BA + 8: Incremental Encoder 3 MSB (Read/Write)

This port accesses the bottom eight bits of the Incremental Encoder 3 16-bit up/down counter. A read provides the current LSB value in the counter. A write loads the bottom eight bits of a starting value into the counter. When writing an initial value to the counter, you must first disable the Incremental Encoder input by setting BA + 11, bits 6 and 5 to 00.

Note that before doing a read of this register, you should first issue a hold command (at BA + 10) to ensure that you do not read the chip in the middle of a count. Also, when reading the count, be sure to read the LSB first, followed by the MSB.

D7	D6	D5	D4	D3	D2	D1	D0
Bit 7	Bit 6	Bit 5	Bit 4	Bit 3	Bit 2	Bit 1	Bit 0

BA + 9: Incremental Encoder 3 MSB (Read/Write)

This port accesses the top eight bits of the Incremental Encoder 3 16-bit up/down counter. A read provides the current MSB value in the counter. A write loads the top eight bits of a starting value into the counter. When writing an initial value to the counter, you must first disable the Incremental Encoder input by setting BA + 11, bits 6 and 5 to 00.

Note that before doing a read of this register, you should first issue a hold command (at BA + 10) to ensure that you do not read the chip in the middle of a count. Also, when reading the count, be sure to read the LSB first, followed by the MSB.

D7	D6	D5	D4	D3	D2	D1	D0
Bit 15	Bit 14	Bit 13	Bit 12	Bit 11	Bit 10	Bit 9	Bit 8

BA + 10: Incremental Encoder 3 Clear/Hold/Digital I/O (Read/Write)

This port controls three different functions of the Incremental Encoder 3 chip. The function performed at this address depends on the setting of bits 1 and 0 at BA + 11.

If BA + 11, bits 1 and 0 are 00, a read clears the Incremental Encoder 3 IRQ status flag, and a write at this address clears the chip. Clearing the IRQ status flag simply resets the flag to 0. Clearing the entire chip resets the IRQ status flag to 0, sets all digital I/O lines for input, and clears the contents of the 16-bit Incremental Encoder 3 counter.

If BA + 11, bits 1 and 0 are 01, a write at this address commands the Incremental Encoder 3 counter to latch its current count value in a hold register. A read is ignored.

If BA + 11, bits 1 and 0 are 10, a read at this address returns the value of the six digital input lines plus P4.0 and P4.1 if they are set up as digital input lines, and a write sends a value out to P4.0 and P4.1 if they are set up as digital output lines.

Digital I/O Register (BA + 11, bits 1 and 0 = 10):

D7	D6	D5	D4	D3	D2	D1	D0
P5.3 Input only	P5.2 Input only	P5.1 Input only	P5.0 Input only	P4.3 Input only	P4.2 Input only	P4.1 Input/ Output	P4.0 Input/ Output

BA + 11: Incremental Encoder 3 Chip Mode Register (Read/Write)

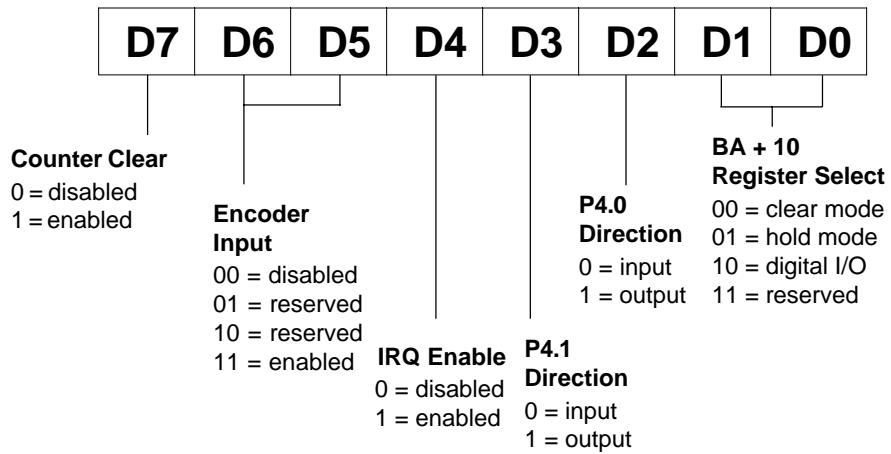

- Bits 0 and 1 – Select clear mode, hold mode, or digital I/O mode for operations performed at BA + 10.
- Bit 2 – Sets the direction of the P4.0 digital line.
- Bit 3 – Sets the direction of the P4.1 digital line.
- Bit 4 – Disables/enables the interrupt circuit on the Incremental Encoder 3 chip. The IRQ channel is determined by the jumper setting on P4.
- Bits 5 and 6 – Disables/enables the Incremental Encoder 3 input pulse.
- Bit 7 – This bit is used to enable digital input P4.2 as a signal that can be used to clear the incremental encoder counter. When this bit is high and the P4.2 input is held high, the counter is held in reset. When the P4.2 line is low, the counters count normally. If this bit is kept low, the P4.2 line has no affect on the counter. This function is normally connected to the index pulse from the incremental encoder.

A read returns the current settings of the bits.

BA + 12: 8254 Timer/Counter 0 (Read/Write)

This address is used to read/write timer/counter 0. A read shows the count in the counter, and a write loads the counter with a new value. Counting begins as soon as the count is loaded.

BA + 13: 8254 Timer/Counter 1 (Read/Write)

This address is used to read/write timer/counter 1. A read shows the count in the counter, and a write loads the counter with a new value. Counting begins as soon as the count is loaded.

BA + 14: 8254 Timer/Counter 2 (Read/Write)

This address is used to read/write timer/counter 2. A read shows the count in the counter, and a write loads the counter with a new value. Counting begins as soon as the count is loaded.

BA + 15: 8254 Timer/Counter Control Word (Write Only)

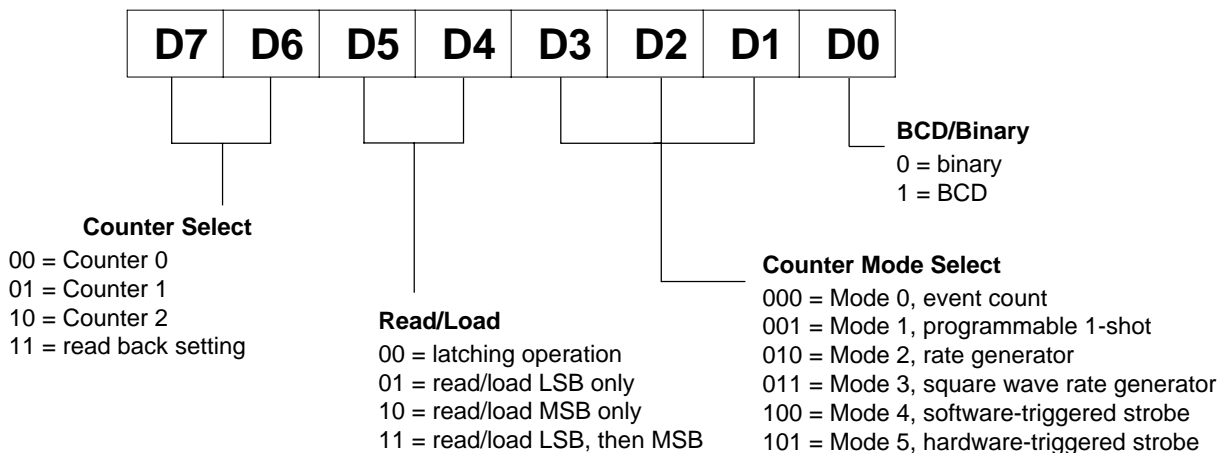

This address is used to write to the control register for the 8254. The control word is defined above.

BA + 16: Clear IRQ/IRQ Enable (Read/Write)

A read clears the P14 jumper-selectable IRQ status flag at BA + 17, bit 3.

IRQ Enable Register:

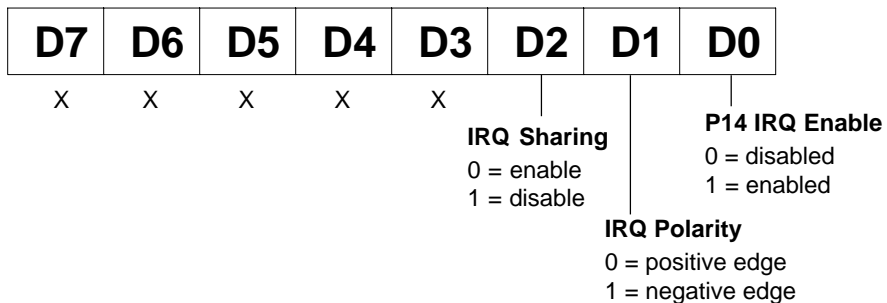

A write enables P14 interrupts and selects whether the interrupt will occur on the positive (rising) edge or negative (falling) edge of the pulse. Bit 2 is used to enable and disable the interrupt sharing circuit. If you are not using shared interrupts, it is best to disable this feature to ensure compatibility with all CPUs.

BA + 17: IRQ Status (Read Only)

A read shows the status of the three Incremental Encoder interrupts and also the jumper-selectable interrupt circuit.

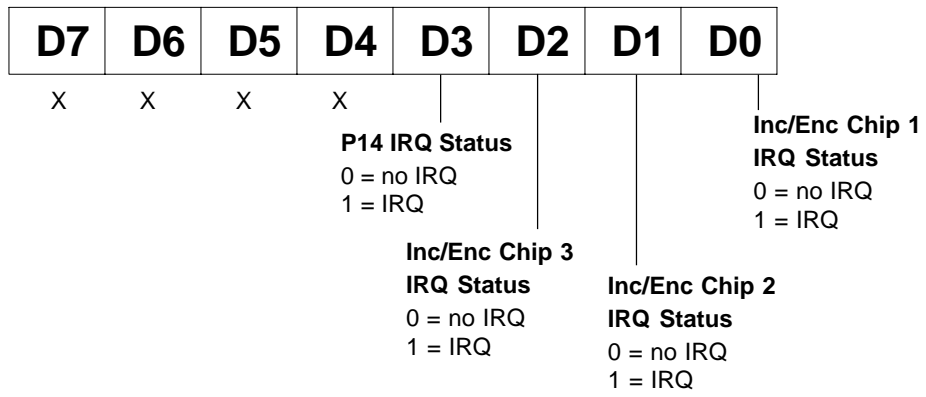

BA + 18: Reserved

BA + 19: Reserved

Programming the DM5814

This section gives you some general information about programming and the DM5814.

The module is programmed by reading from and writing to the correct I/O port locations. These I/O ports were defined in the previous section. Most high-level languages such as BASIC, Pascal, C, and C++, and of course assembly language, make it very easy to read/write these ports. The table below shows you how to read from and write to I/O ports using some popular programming languages.

Language	Read	Write
BASIC	Data=INP(Address)	OUT Address,Data
Turbo C	Data=inportb(Address)	outportb(Address,Data)
Turbo Pascal	Data:=Port[Address]	Port[Address]:=Data
Assembly	mov dx,Address in al,dx	mov dx,Address mov al,Data out dx,al

In addition to being able to read/write the I/O ports on the DM5814, you must be able to perform a variety of operations that you might not normally use in your programming. The table below shows you some of the operators discussed in this section, with an example of how each is used with C, Pascal, and BASIC. Note that the modulus operator is used to retrieve the least significant byte (LSB) of a two-byte word, and the integer division operator is used to retrieve the most significant byte (MSB).

Language	Modulus	Integer Division	AND	OR
C	% a = b % c	/ a = b / c	& a = b & c	 a = b c
Pascal	MOD a := b MOD c	DIV a := b DIV c	AND a := b AND c	OR a := b OR c
BASIC	MOD a = b MOD c	\ a = b \ c	AND a = b AND c	OR a = b OR c

Many compilers have functions that can read/write either 8 or 16 bits from/to an I/O port. For example, Turbo Pascal uses **Port** for 8-bit port operations and **PortW** for 16 bits, Turbo C uses **inportb** for an 8-bit read of a port and **inport** for a 16-bit read. **Be sure to use only 8-bit operations with the DM5814!**

Clearing and Setting Bits in a Port

When you clear or set one or more bits in a port, you must be careful that you do not change the status of the other bits. You can preserve the status of all bits you do not wish to change by proper use of the AND and OR binary operators. Using AND and OR, single or multiple bits can be easily cleared in one operation. Note that most registers in the DM5814 cannot be read back; therefore, you must save the value in your program.

To **clear** a single bit in a port, AND the current value of the port with the value b, where $b = 255 - 2^{\text{bit}}$.

Example: Clear bit 5 in a port. Read in the current value of the port, AND it with 223 ($223 = 255 - 2^5$), and then write the resulting value to the port. In BASIC, this is programmed as:

```
V_SAVE = V_SAVE AND 223
OUT PortAddress, V
```

To **set** a single bit in a port, OR the current value of the port with the value b, where $b = 2^{\text{bit}}$.

Example: Set bit 3 in a port. Read in the current value of the port, OR it with 8 ($8 = 2^3$), and then write the resulting value to the port. In Pascal, this is programmed as:

```
V_Save = V_Save OR 8;  
Port[PortAddress] := V_Save;
```

Setting or clearing more than one bit at a time is accomplished just as easily. To **clear** multiple bits in a port, AND the current value of the port with the value b, where $b = 255 -$ (the sum of the values of the bits to be cleared). Note that the bits do not have to be consecutive.

Example: Clear bits 2, 4, and 6 in a port. Read in the current value of the port, AND it with 171 ($171 = 255 - 2^2 - 2^4 - 2^6$), and then write the resulting value to the port. In C, this is programmed as:

```
v_save = v_save & 171;  
outportb(port_address, v_save);
```

To **set** multiple bits in a port, OR the current value of the port with the value b, where b = the sum of the individual bits to be set. Note that the bits to be set do not have to be consecutive.

Example: Set bits 3, 5, and 7 in a port. Read in the current value of the port, OR it with 168 ($168 = 2^3 + 2^5 + 2^7$), and then write the resulting value back to the port. In assembly language, this is programmed as:

```
mov al, v_save  
or al, 168  
mov dx, PortAddress  
out dx, al
```

Often, assigning a range of bits is a mixture of setting and clearing operations. You can set or clear each bit individually or use a faster method of first clearing all the bits in the range then setting only those bits that must be set using the method shown above for setting multiple bits in a port. The following example shows how this two-step operation is done.

Example: Assign bits 3, 4, and 5 in a port to 101 (bits 3 and 5 set, bit 4 cleared). First, read in the port and clear bits 3, 4, and 5 by ANDing them with 199. Then set bits 3 and 5 by ORing them with 40, and finally write the resulting value back to the port. In C, this is programmed as:

```
v_save = v_save & 199;  
v_save = v_save | 40;  
outportb(port_address, v_save);
```

A final note: Don't be intimidated by the binary operators AND and OR and try to use operators for which you have a better intuition. For instance, if you are tempted to use addition and subtraction to set and clear bits in place of the methods shown above, DON'T! Addition and subtraction may seem logical, but they **will not work** if you try to clear a bit that is already clear or set a bit that is already set. For example, you might think that to set bit 5 of a port, you simply need to read in the port, add 32 (2^5) to that value, and then write the resulting value back to the port. This works fine if bit 5 is not already set. But, what happens when bit 5 *is* already set? Bits 0 to 4 will be unaffected and we can't say for sure what happens to bits 6 and 7, but we can say for sure that bit 5 ends up cleared instead of being set. A similar problem happens when you use subtraction to clear a bit in place of the method shown above.

CHAPTER 5

DIGITAL I/O

This chapter explains the digital I/O circuitry on the DM5814.

The DM5814 has eight TTL/CMOS digital I/O lines available for digital control applications on each of the three Incremental Encoder chips. Six lines can be programmed as input only, and two lines can be programmed as input/output. Chapter 4 shows how to program these lines.

CHAPTER 6

TIMER/COUNTERS

This chapter explains the 8254 timer/counter circuit on the DM5814.

An 8254 programmable interval timer provides three 16-bit, 8-MHz timers for timing and counting functions such as frequency measurement, event counting, and interrupts. These timer/counters can be configured in a number of ways to support your application. Figure 6-1 shows a block diagram of the timer/counter circuitry.

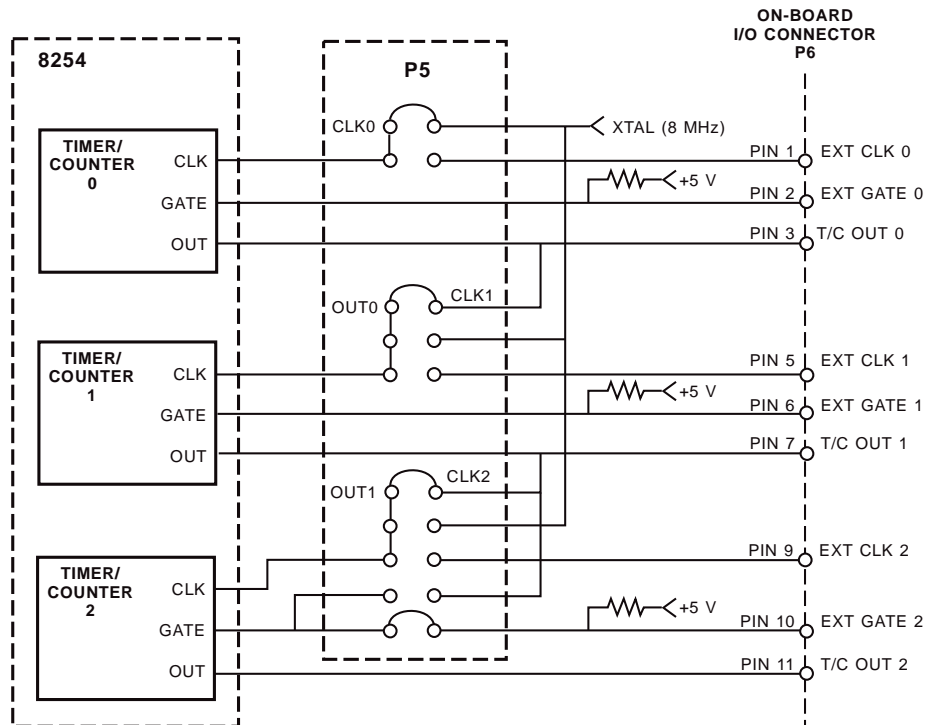

Fig. 9-1 — 8254 Timer/Counter Circuit Block Diagram

Each timer/counter has two inputs, CLK in and GATE in, and one output, timer/counter OUT. They can be programmed as binary or BCD down counters by writing the appropriate data to the command word, as described in the I/O map discussion in Chapter 4.

The timer/counter outputs are available at P6 where they can be used for interrupt generation, as an A/D trigger, or for timing and counting functions.

The timers can be programmed to operate in one of six modes, depending on your application. The following paragraphs briefly describe each mode.

Mode 0, Event Counter (Interrupt on Terminal Count). This mode is typically used for event counting. While the timer/counter counts down, the output is low, and when the count is complete, it goes high. The output stays high until a new Mode 0 control word is written to the timer/counter.

Mode 1, Hardware-Retriggerable One-Shot. The output is initially high and goes low on the clock pulse following a trigger to begin the one-shot pulse. The output remains low until the count reaches 0, and then goes high and remains high until the clock pulse after the next trigger.

Mode 2, Rate Generator. This mode functions like a divide-by-N counter and is typically used to generate a real-time clock interrupt. The output is initially high, and when the count decrements to 1, the output goes low for one clock pulse. The output then goes high again, the timer/counter reloads the initial count, and the process is repeated. This sequence continues indefinitely.

Mode 3, Square Wave Mode. Similar to Mode 2 except for the duty cycle output, this mode is typically used for baud rate generation. The output is initially high, and when the count decrements to one-half its initial count, the output goes low for the remainder of the count. The timer/counter reloads and the output goes high again. This process repeats indefinitely.

Mode 4, Software-Triggered Strobe. The output is initially high. When the initial count expires, the output goes low for one clock pulse and then goes high again. Counting is “triggered” by writing the initial count.

Mode 5, Hardware Triggered Strobe (Retriggerable). The output is initially high. Counting is triggered by the rising edge of the gate input. When the initial count has expired, the output goes low for one clock pulse and then goes high again.

Appendix C provides the 8254 data sheet.

CHAPTER 7

INTERRUPTS

This chapter explains P14 jumper selectable interrupts and basic interrupt programming techniques.

The DM5814 has four interrupt circuits which can generate interrupts on any IRQ channel 2 through 7, depending on the setting of the jumper on P4.

P14: Jumper Selectable Interrupts

The DM5814 circuitry has four jumper selectable interrupt sources which can be set by installing a jumper across the desired pair of pins at P14.

To use these interrupts, an interrupt source must be jumpered on P14, an interrupt channel must be jumpered on P4, and the IRQ enable must be set high (BA + 16, bit 0). BA + 16, bit 1 sets the polarity of the interrupt.

Incremental Encoder Interrupts

Each Incremental Encoder chip is capable of also generating an interrupt. The interrupt source for each chip is connected through the I/O connector P2 on pins 33, 17 and 1.

To use these interrupts, an interrupt source must be connected to P2, an interrupt channel must be jumpered on P4, and the IRQ enable for the corresponding chip must be set high (BA + 3, bit 4; BA + 7, bit 4; BA + 11, bit 4). You can read the status byte at BA + 17 to determine which circuit caused the interrupt and issue the proper clear interrupt command.

Each chip also has an overflow/underflow output on P2 pins 35, 19, 3. This output will generate a pulse each time the Incremental Encoder counts past 65535 or below 0. This pin can be connected back to the interrupt input to generate an interrupt on overflow/underflow.

Selecting the Interrupt Channel

The IRQ channel is selected by installing a jumper on header connector P4 or P16 across the desired pair of pins, as described in Chapter 1. A jumper is also installed across the G pins if you are using the interrupt sharing feature. The jumper selectable interrupt source and the Incremental Encoder interrupt sources are "OR'd" together and can use the same interrupt channel.

To determine which interrupt source has generated an interrupt, you must check bits 0 through 3 of the status byte read at BA + 17. Then service the interrupt that has occurred and clear the interrupt (the jumper selectable interrupt is cleared by reading BA + 16, and the digital interrupts are cleared by setting bits 1 and 0 in the corresponding Inc/Enc Control Register and performing a read at the Clear/Hold Register address).

Interrupt Sharing

This module is capable of sharing interrupts with multiple modules. This circuit is described in chapter 1. If you are not planning on using shared interrupts or you are not sure that your CPU can support shared interrupts, you should disable this sharing circuit by setting bit 2 at BA + 16 to a "1". By doing this the board works in normal interrupt mode and is compatible with all CPUs.

Basic Programming For Interrupt Handling

What Is an Interrupt?

An interrupt is an event that causes the processor in your computer to temporarily halt its current process and execute another routine. Upon completion of the new routine, control is returned to the original routine at the point where its execution was interrupted.

Interrupts are very handy for dealing with asynchronous events (events that occur at less than regular intervals). Keyboard activity is a good example; your computer cannot predict when you might press a key and it would be a waste of processor time for it to do nothing while waiting for a keystroke to occur. Thus, the interrupt scheme is used and the processor proceeds with other tasks. Then, when a keystroke does occur, the keyboard ‘interrupts’ the processor, and the processor gets the keyboard data, places it in memory, and then returns to what it was doing before it was interrupted. Other common devices that use interrupts are modems, disk drives, and mice.

Your DM5814 can interrupt the processor when a variety of conditions are met. By using these interrupts, you can write software that effectively deals with real world events.

Interrupt Request Lines

To allow different peripheral devices to generate interrupts on the same computer, the PC bus has eight different interrupt request (IRQ) lines. A transition from low to high on one of these lines generates an interrupt request which is handled by the PC’s interrupt controller. The interrupt controller checks to see if interrupts are to be acknowledged from that IRQ and, if another interrupt is already in progress, it decides if the new request should supersede the one in progress or if it has to wait until the one in progress is done. This prioritizing allows an interrupt to be interrupted if the second request has a higher priority. The priority level is based on the number of the IRQ; IRQ0 has the highest priority, IRQ1 is second-highest, and so on through IRQ7, which has the lowest. Many of the IRQs are used by the standard system resources. IRQ0 is used by the system timer, IRQ1 is used by the keyboard, IRQ3 by COM2, IRQ4 by COM1, and IRQ6 by the disk drives. Therefore, it is important for you to know which IRQ lines are available in your system for use by the module.

8259 Programmable Interrupt Controller

The chip responsible for handling interrupt requests in the PC is the 8259 Programmable Interrupt Controller. To use interrupts, you need to know how to read and set the 8259’s interrupt mask register (IMR) and how to send the end-of-interrupt (EOI) command to the 8259.

- Interrupt Mask Register (IMR)

Each bit in the interrupt mask register (IMR) contains the mask status of an IRQ line; bit 0 is for IRQ0, bit 1 is for IRQ1, and so on. If a bit is **set** (equal to 1), then the corresponding IRQ is masked and it will not generate an interrupt. If a bit is **clear** (equal to 0), then the corresponding IRQ is unmasked and can generate interrupts. The IMR is programmed through port 21H.

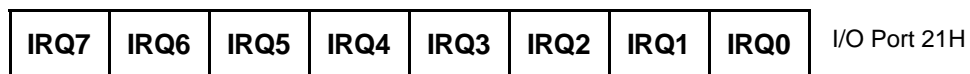

For all bits:

0 = IRQ unmasked (enabled)

1 = IRQ masked (disabled)

- End-of-Interrupt (EOI) Command

After an interrupt service routine is complete, the 8259 interrupt controller must be notified. This is done by writing the value 20H to I/O port 20H.

What Exactly Happens When an Interrupt Occurs?

Understanding the sequence of events when an interrupt is triggered is necessary to properly write software interrupt handlers. When an interrupt request line is driven high by a peripheral device (such as the DM5814), the interrupt controller checks to see if interrupts are enabled for that IRQ, and then checks to see if other interrupts are active or requested and determines which interrupt has priority. The interrupt controller then interrupts the processor. The current code segment (CS), instruction pointer (IP), and flags are pushed on the stack for storage, and a new CS and IP are loaded from a table that exists in the lowest 1024 bytes of memory. This table is referred to as the interrupt vector table and each entry is called an interrupt vector. Once the new CS and IP are loaded from the interrupt vector table, the processor begins executing the code located at CS:IP. When the interrupt routine is completed, the CS, IP, and flags that were pushed on the stack when the interrupt occurred are now popped from the stack and execution resumes from the point where it was interrupted.

Using Interrupts in Your Programs

Adding interrupts to your software is not as difficult as it may seem, and what they add in terms of performance is often worth the effort. Note, however, that although it is not that hard to use interrupts, the smallest mistake will often lead to a system hang that requires a reboot. This can be both frustrating and time-consuming. But, after a few tries, you'll get the bugs worked out and enjoy the benefits of properly executed interrupts. In addition to reading the following paragraphs, study the INTRPTS source code included on your DM5814 program disk for a better understanding of interrupt program development.

Writing an Interrupt Service Routine (ISR)

The first step in adding interrupts to your software is to write the interrupt service routine (ISR). This is the routine that will automatically be executed each time an interrupt request occurs on the specified IRQ. An ISR is different than standard routines that you write. First, on entrance, the processor registers should be pushed onto the stack **BEFORE** you do anything else. Second, just before exiting your ISR, you must clear the interrupt status flag of the DM5814 and write an end-of-interrupt command to the 8259 controller. Finally, when exiting the ISR, in addition to popping all the registers you pushed on entrance, you must use the IRET instruction and **not** a plain RET. The IRET automatically pops the flags, CS, and IP that were pushed when the interrupt was called.

If you find yourself intimidated by interrupt programming, take heart. Most Pascal and C compilers allow you to identify a procedure (function) as an interrupt type and will automatically add these instructions to your ISR, with one important exception: most compilers **do not** automatically add the end-of-interrupt command to the procedure; you must do this yourself. Other than this and the few exceptions discussed below, you can write your ISR just like any other routine. It can call other functions and procedures in your program and it can access global data. If you are writing your first ISR, we recommend that you stick to the basics; just something that will convince you that it works, such as incrementing a global variable.

NOTE: If you are writing an ISR using assembly language, you are responsible for pushing and popping registers and using IRET instead of RET.

There are a few cautions you must consider when writing your ISR. The most important is, **do not use any DOS functions or routines that call DOS functions from within an ISR**. DOS is **not** reentrant; that is, a DOS function cannot call itself. In typical programming, this will not happen because of the way DOS is written. But what about when using interrupts? Then, you could have a situation such as this in your program. If DOS function X is being executed when an interrupt occurs and the interrupt routine makes a call to DOS function X, then function X is essentially being called while it is already active. Such a reentrancy attempt spells disaster because DOS functions are not written to support it. This is a complex concept and you do not need to understand it. Just make sure that you do not call any DOS functions from within your ISR. The one wrinkle is that, unfortunately, it is not obvious which library routines included with your compiler use DOS functions. A rule of thumb is that routines which write to the screen, or check the status of or read the keyboard, and any disk I/O routines use DOS and should be avoided in your ISR.

The same problem of reentrancy exists for many floating point emulators as well, meaning you may have to avoid floating point (real) math in your ISR.

Note that the problem of reentrancy exists, no matter what programming language you are using. Even if you are writing your ISR in assembly language, DOS and many floating point emulators are not reentrant. Of course, there are ways around this problem, such as those which involve checking to see if any DOS functions are currently active when your ISR is called, but such solutions are well beyond the scope of this discussion.

The second major concern when writing your ISR is to make it as short as possible in terms of execution time. Spending long periods of time in your ISR may mean that other important interrupts are being ignored. Also, if you spend too long in your ISR, it may be called again before you have completed handling the first run. This often leads to a hang that requires a reboot.

Your ISR should have this structure:

- Push any processor registers used in your ISR. Most C and Pascal interrupt routines automatically do this for you.
- Put the body of your routine here.
- Clear the interrupt status flag.
- Issue the EOI command to the 8259 interrupt controller by writing 20H to port 20H.
- Pop all registers pushed on entrance. Most C and Pascal interrupt routines automatically do this for you.

The following C and Pascal examples show what the shell of your ISR should be like. Only the clear interrupt command sequence for the source which caused the interrupt needs to be included:

In C:

```
void interrupt ISR(void)
{
    /* Your code goes here. Do not use any DOS functions! */
    inportb(BaseAddress + 16);          /* Clear jumper selectable interrupt */
    outportb(0x20, 0x20);              /* Send EOI command to 8259 */
}
```

In Pascal:

```
Procedure ISR; Interrupt;
begin
    { Your code goes here. Do not use any DOS functions! }
    c := Port[BaseAddress + 16];      { Clear jumper selectable interrupt }
    Port[$20] := $20;                 { Send EOI command to 8259 }
end;
```

Saving the Startup Interrupt Mask Register (IMR) and Interrupt Vector

The next step after writing the ISR is to save the startup state of the interrupt mask register and the interrupt vector that you will be using. The IMR is located at I/O port 21H. The interrupt vector you will be using is located in the interrupt vector table which is simply an array of 256-bit (4-byte) pointers and is located in the first 1024 bytes of memory (Segment = 0, Offset = 0). You can read this value directly, but it is a better practice to use DOS function 35H (get interrupt vector). Most C and Pascal compilers provide a library routine for reading the value of a vector. The vectors for the hardware interrupts are vectors 8 through 15, where IRQ0 uses vector 8, IRQ1 uses vector 9, and so on. Thus, if the DM5814 will be using IRQ3, you should save the value of interrupt vector 11.

Before you install your ISR, temporarily mask out the IRQ you will be using. This prevents the IRQ from requesting an interrupt while you are installing and initializing your ISR. To mask the IRQ, read in the current IMR at I/O port 21H and **set** the bit that corresponds to your IRQ (remember, setting a bit disables interrupts on that IRQ while clearing a bit enables them). The IMR is arranged so that bit 0 is for IRQ0, bit 1 is for IRQ1, and so on. See the paragraph entitled *Interrupt Mask Register (IMR)* earlier in this chapter for help in determining your IRQ's bit. After setting the bit, write the new value to I/O port 21H.

With the startup IMR saved and the interrupts on your IRQ temporarily disabled, you can assign the interrupt vector to point to your ISR. Again, you can overwrite the appropriate entry in the vector table with a direct memory

write, but this is a bad practice. Instead, use either DOS function 25H (set interrupt vector) or, if your compiler provides it, the library routine for setting an interrupt vector. Remember that vector 8 is for IRQ0, vector 9 is for IRQ1, and so on.

If you need to program the source of your interrupts, do that next. For example, if you are using the programmable interval timer to generate interrupts, you must program it to run in the proper mode and at the proper rate.

Finally, clear the bit in the IMR for the IRQ you are using. This enables interrupts on the IRQ.

Restoring the Startup IMR and Interrupt Vector

Before exiting your program, you must restore the interrupt mask register and interrupt vectors to the state they were in when your program started. To restore the IMR, write the value that was saved when your program started to I/O port 21H. Restore the interrupt vector that was saved at startup with either DOS function 35H (get interrupt vector), or use the library routine supplied with your compiler. Performing these two steps will guarantee that the interrupt status of your computer is the same after running your program as it was before your program started running.

Common Interrupt Mistakes

- Remember that hardware interrupts are numbered 8 through 15, even though the corresponding IRQs are numbered 0 through 7.
- Two of the most common mistakes when writing an ISR are forgetting to clear the interrupt status of the DM5814 and forgetting to issue the EOI command to the 8259 interrupt controller before exiting the ISR.

APPENDIX A

DM5814/DM6814 SPECIFICATIONS

DM5814/DM6814 Characteristics Typical @ 25° C

Interface

Switch-selectable base address, I/O mapped
Jumper-selectable interrupts

Incremental Encoder Interface

Number of channels 3
Counter size 16-bits
Input rate 1 MHz
Input type TTL
Input level 0 - +5 volts

Digital I/O

Number of lines 6 bit programmable
I/O type TTL
Input/Output levels 0 - +5 volts
Isource -12 mA
Isink 24 mA

Digital Inputs

Number of lines 18
Input levels 0 - +5 volts

Timer/Counters CMOS 82C54

Three 16-bit down counters
6 programmable operating modes
Counter input source External clock (8 MHz, max) or
on-board 8-MHz clock
Counter outputs Available externally; used as PC interrupts
Counter gate source External gate or always enabled

Miscellaneous Inputs/Outputs (PC bus-sourced)

+5 volts, ground

Power Requirements

+5V @ 238 mA = 1.18W typical

Connectors

P2 and P3: 50-pin right angle header
P6: 12-pin box header

Environmental

Operating temperature 0 to +70°C
Storage temperature -40 to +85°C
Humidity 0 to 90% non-condensing

Size

3.55"L x 3.775"W x 0.6"H (90mm x 96mm x 15mm)

APPENDIX B

CONNECTOR PIN ASSIGNMENTS

P2 Connector:

INC ENC3 IRQIN	(1)	(2)	EXT INT 1
OVERFLOW3 OUT	(3)	(4)	DIGITAL GND
INC ENC3 CHB	(5)	(6)	DIGITAL GND
INC ENC3 CHA	(7)	(8)	DIGITAL GND
P4.3	(9)	(10)	DIGITAL GND
P4.2	(11)	(12)	DIGITAL GND
P4.1	(13)	(14)	DIGITAL GND
P4.0	(15)	(16)	DIGITAL GND
INC ENC2 IRQIN	(17)	(18)	DIGITAL GND
OVERFLOW2 OUT	(19)	(20)	DIGITAL GND
INC ENC2 CHB	(21)	(22)	DIGITAL GND
INC ENC2 CHA	(23)	(24)	DIGITAL GND
P2.3	(25)	(26)	DIGITAL GND
P2.2	(27)	(28)	DIGITAL GND
P2.1	(29)	(30)	DIGITAL GND
P2.0	(31)	(32)	DIGITAL GND
INC ENC1 IRQIN	(33)	(34)	DIGITAL GND
OVERFLOW1 OUT	(35)	(36)	DIGITAL GND
INC ENC1 CHB	(37)	(38)	DIGITAL GND
INC ENC1 CHA	(39)	(40)	DIGITAL GND
P0.3	(41)	(42)	DIGITAL GND
P0.2	(43)	(44)	DIGITAL GND
P0.1	(45)	(46)	DIGITAL GND
P0.0	(47)	(48)	DIGITAL GND
+5 VOLTS	(49)	(50)	DIGITAL GND

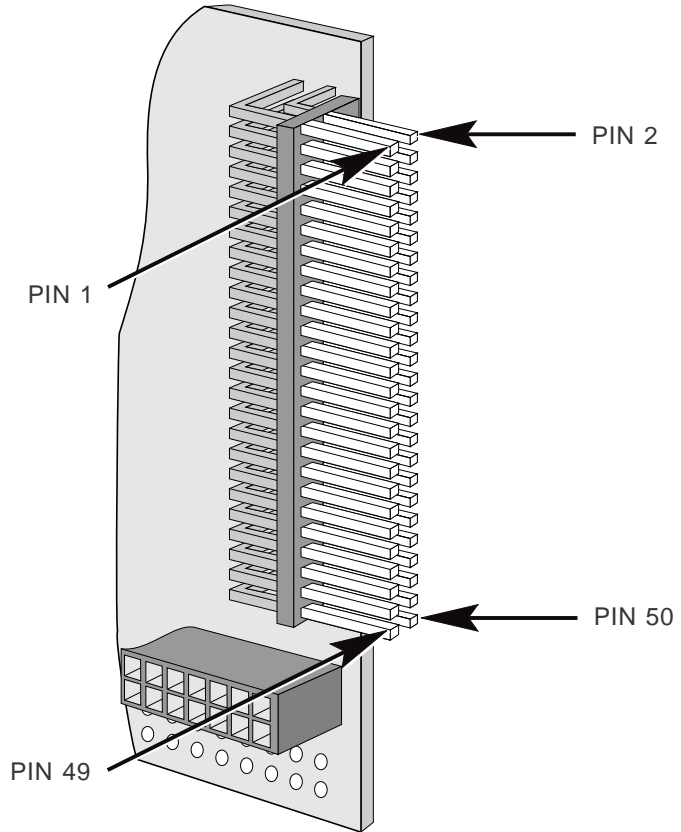

P3 Connector:

N.C.	(1)	(2)	EXT INT 2
N.C.	(3)	(4)	DIGITAL GND
N.C.	(5)	(6)	DIGITAL GND
N.C.	(7)	(8)	DIGITAL GND
P5.3	(9)	(10)	DIGITAL GND
P5.2	(11)	(12)	DIGITAL GND
P5.1	(13)	(14)	DIGITAL GND
P5.0	(15)	(16)	DIGITAL GND
N.C.	(17)	(18)	DIGITAL GND
N.C.	(19)	(20)	DIGITAL GND
N.C.	(21)	(22)	DIGITAL GND
N.C.	(23)	(24)	DIGITAL GND
P3.3	(25)	(26)	DIGITAL GND
P3.2	(27)	(28)	DIGITAL GND
P3.1	(29)	(30)	DIGITAL GND
P3.0	(31)	(32)	DIGITAL GND
N.C.	(33)	(34)	DIGITAL GND
N.C.	(35)	(36)	DIGITAL GND
N.C.	(37)	(38)	DIGITAL GND
N.C.	(39)	(40)	DIGITAL GND
P1.3	(41)	(42)	DIGITAL GND
P1.2	(43)	(44)	DIGITAL GND
P1.1	(45)	(46)	DIGITAL GND
P1.0	(47)	(48)	DIGITAL GND
+5 VOLTS	(49)	(50)	DIGITAL GND

P2 & P3 Mating Connector Part Numbers	
Manufacturer	Part Number
AMP	1-746094-0
3M	3425-7650

P6 Connector:

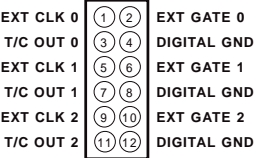

APPENDIX C

COMPONENT DATA SHEETS

**Intel 82C54 Programmable Interval Timer
Data Sheet Reprint**

APPENDIX D

OPTIONAL DM5814 CONFIGURATIONS

Mixing Incremental Encoder Chips and Digital I/O Circuits on the Same Module

You can order the DM5814 with one, two, or three Incremental Encoder chips. When you order a DM5814 with less than three Incremental Encoder chips, each chip not on the module is replaced by a 16-bit digital I/O circuit. For example, a module might have two Encoder chips and one digital I/O circuit, or one Encoder chip and two digital I/O circuits. To make matters just a little more complex, you can order the module with 16-bit digital I/O circuits that are 16 bit programmable I/O lines, or a mixture of 8 bit programmable lines and 8 byte programmable lines. This Appendix shows the I/O mapping for programming these digital I/O lines when they are installed in place of any of the Incremental Encoder chips.

I/O Mapping for 16 Bit Programmable I/O Lines

When you replace any Incremental Encoder chip with a circuit that has 16 bit programmable digital I/O lines, you should use the I/O maps and programming description that follows as required to program these lines.

I/O Map 1: When Replacing Incremental Encoder Chip 1 with a 16 Bit Programmable Circuit:

Register Description	Read Function	Write Function	Address * (Decimal)
Digital I/O Port 0	Read Port 0 digital input lines	Program Port 0 digital output lines	BA + 0
Digital I/O Port 1	Read Port 1 digital input lines	Program Port 1 digital output lines	BA + 1
Clear IRQ/Program Port Direction & IRQ Source	Clear digital IRQ status flag/read Port 0 direction, Port 1 direction or IRQ source (dependent on BA + 3)	Clear digital chip/program Port 0 direction, Port 1 direction or IRQ source (dependent on BA + 3)	BA + 2
Read Digital IRQ Status/ Set Digital Control Register	Read digital interrupt status word	Program digital control register	BA + 3

I/O Map 2: When Replacing Incremental Encoder Chip 2 with a 16 Bit Programmable Circuit:

Register Description	Read Function	Write Function	Address * (Decimal)
Digital I/O Port 2	Read Port 2 digital input lines	Program Port 2 digital output lines	BA + 4
Digital I/O Port 3	Read Port 3 digital input lines	Program Port 3 digital output lines	BA + 5
Clear IRQ/Program Port Direction & IRQ Source	Clear digital IRQ status flag/read Port 2 direction, Port 3 direction or IRQ source (dependent on BA + 7)	Clear digital chip/program Port 2 direction, Port 3 direction or IRQ source (dependent on BA + 7)	BA + 6
Read Digital IRQ Status/ Set Digital Control Register	Read digital interrupt status word	Program digital control register	BA + 7

I/O Map 3: When Replacing Incremental Encoder Chip 3 with a 16 Bit Programmable Circuit:

Register Description	Read Function	Write Function	Address * (Decimal)
Digital I/O Port 4	Read Port 4 digital input lines	Program Port 4 digital output lines	BA + 8
Digital I/O Port 5	Read Port 5 digital input lines	Program Port 5 digital output lines	BA + 9
Clear IRQ/Program Port Direction & IRQ Source	Clear digital IRQ status flag/read Port 4 direction, Port 5 direction or IRQ source (dependent on BA + 11)	Clear digital chip/program Port 4 direction, Port 5 direction or IRQ source (dependent on BA + 11)	BA + 10
Read Digital IRQ Status/ Set Digital Control Register	Read digital interrupt status word	Program digital control register	BA + 11

BA + 0, 4, 8: Digital I/O Port (Read/Write)

This port transfers the 8-bit Port 0, 2, or 4 bit programmable digital input/output data between the module and external devices. The bits are individually programmed as input or output by writing to the Port 0, 2, or 4 Direction Register at BA + 2, 6, or 10. For all bits set as inputs, a read reads the input values and a write is ignored. For all bits set as outputs, a read reads the last value sent out on the line and a write writes the current loaded value out to the line.

Note that when any reset of the digital circuitry is performed (clear chip or computer reset), all digital lines are reset to inputs and their corresponding output registers are cleared.

D7	D6	D5	D4	D3	D2	D1	D0
P0.7	P0.6	P0.5	P0.4	P0.3	P0.2	P0.1	P0.0
P2.7	P2.6	P2.5	P2.4	P2.3	P2.2	P2.1	P2.0
P4.7	P4.6	P4.5	P4.4	P4.3	P4.2	P4.1	P4.0

BA + 1, 5, 9: Digital I/O Port (Read/Write)

This port transfers the 8-bit Port 1, 3, or 5 bit programmable digital input/output data between the module and external devices. The bits are individually programmed as input or output by writing to the Port 1, 3, or 5 Direction Register at BA + 2, 6, or 10. For all bits set as inputs, a read reads the input values and a write is ignored. For all bits set as outputs, a read reads the last value sent out on the line and a write writes the current loaded value out to the line.

Note that when any reset of the digital circuitry is performed (clear chip or computer reset), all digital lines are reset to inputs and their corresponding output registers are cleared.

D7	D6	D5	D4	D3	D2	D1	D0
P1.7	P1.6	P1.5	P1.4	P1.3	P1.2	P1.1	P1.0
P3.7	P3.6	P3.5	P3.4	P3.3	P3.2	P3.1	P3.0
P5.7	P5.6	P5.5	P5.4	P5.3	P5.2	P5.1	P5.0

BA + 2, 6, 10: Clear IRQ/Program Port Direction/Port Direction/IRQ Source Registers (Read/Write)

A read clears the IRQ status flag or provides the contents of one of three control registers: Port 0/2/4 Direction, Port 1/3/5 Direction, or Port 0/1, 2/3, or 4/5 chip IRQ Source. A write clears the digital chip or programs one of the three control registers, depending on the setting of bits 0 and 1 at BA + 3, 7, or 11. When bits 1 and 0 at BA + 3, 7, or 11 are 00, the read/write operations clear the digital IRQ status flag (read) and the digital chip (write). When these bits are set to any other value, one of the three Port 0/1, 2/3, or 4/5 digital I/O registers is addressed.

Port Direction Register (BA + 3 (or 7 or 11), bits 1 and 0 = 01):

For all bits:

0 = input

1 = output

D7	D6	D5	D4	D3	D2	D1	D0
P0.7	P0.6	P0.5	P0.4	P0.3	P0.2	P0.1	P0.0
P2.7	P2.6	P2.5	P2.4	P2.3	P2.2	P2.1	P2.0
P4.7	P4.6	P4.5	P4.4	P4.3	P4.2	P4.1	P4.0

This register programs the direction, input or output, of each bit at Port 0, 2, or 4.

Port Direction Register (BA + 3 (or 7 or 11), bits 1 and 0 = 10):

For all bits:

0 = input

1 = output

D7	D6	D5	D4	D3	D2	D1	D0
P1.7	P1.6	P1.5	P1.4	P1.3	P1.2	P1.1	P1.0
P3.7	P3.6	P3.5	P3.4	P3.3	P3.2	P3.1	P3.0
P5.7	P5.6	P5.5	P5.4	P5.3	P5.2	P5.1	P5.0

This register programs the direction, input or output, of each bit at Port 1, 3, or 5.

Chip IRQ Source Register (BA + 3 (or 7 or 11), bits 1 and 0 = 11):

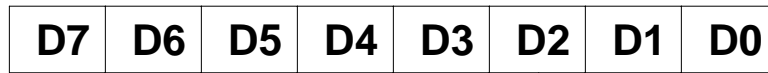

Port 0/1 IRQ Select

FOR PORT 0/1:	0000 = P0.0	0100 = P0.4	1000 = P1.0	1100 = P1.4
	0001 = P0.1	0101 = P0.5	1001 = P1.1	1101 = P1.5
	0010 = P0.2	0110 = P0.6	1010 = P1.2	1110 = P1.6
	0011 = P0.3	0111 = P0.7	1011 = P1.3	1111 = P1.7

This register programs the bit to be used to generate a digital interrupt for the Port 0/1, Port 2/3, or Port 4/5 chip. A digital interrupt is generated when the selected bit goes from low to high (interrupt generated on the positive-going edge).

BA + 3, 7, 11: Read Digital I/O Status/Program Digital Mode (Read/Write)

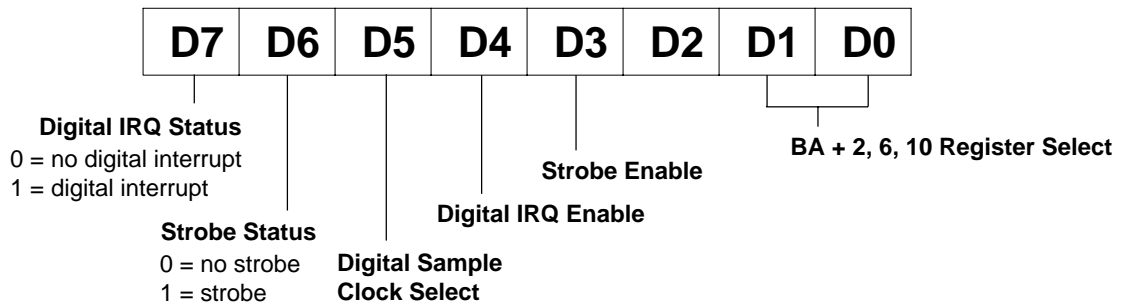

A read shows you whether a digital interrupt has occurred and lets you review the states of the other bits in this register. If bit 7 is high, then a digital interrupt has taken place. This provides the same status information as BA + 17, bits 0 through 2.

Digital Mode Register:

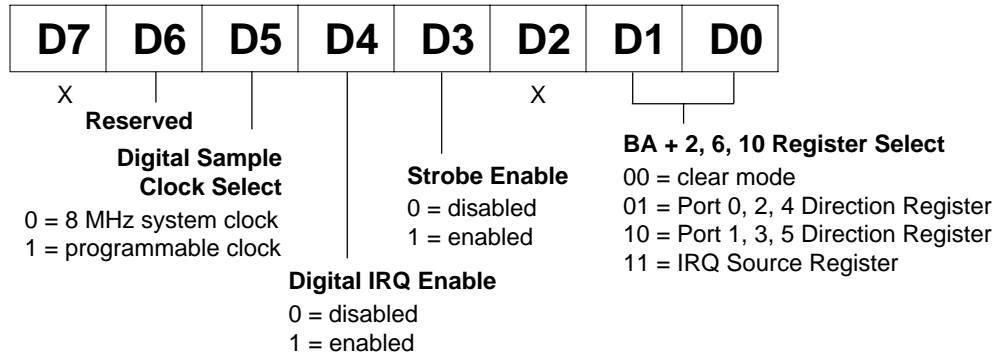

- Bits 0 and 1 – Select the clear mode initiated by a read/write operation at BA + 2, 6, or 10, or the control register you talk to at BA + 2, 6, or 10.
- Bit 3 – Enables EPLD strobe input (used with P13 header, which can be used only for digital I/O circuits, NOT Incremental Encoder circuits).
- Bit 4 – Disables/enables digital interrupts. The IRQ channel is determined by the jumper setting on P4.
- Bit 5 – Sets the clock rate at which the digital lines are sampled when in a digital interrupt mode. Available clock sources are the 8 MHz system clock and the output of the 8254 Counter 1 (16-bit programmable clock). When a digital input line changes state, it must stay at the new state for two edges of the clock pulse (62.5 nanoseconds when using the 8 MHz clock) before it is recognized and before an interrupt can be generated. This feature eliminates noise glitches that can cause a false state change on an input line and generate an unwanted interrupt.
- Bit 6 – Reserved.
- Bit 7 – Read only (digital IRQ status).

I/O Mapping for 16 Bit Programmable I/O Lines

When you replace any Incremental Encoder chip with a circuit that has 16 bit programmable digital I/O lines, you should use the I/O maps and programming description that follows as required to program these lines.

I/O Map 1: When Replacing Incremental Encoder Chip 1 with a 16 Bit Programmable Circuit:

Register Description	Read Function	Write Function	Address * (Decimal)
Digital I/O Port 0	Read Port 0 digital input lines	Program Port 0 digital output lines	BA + 0
Digital I/O Port 1	Read Port 1 digital input lines	Program Port 1 digital output lines	BA + 1
Port 0 Clear/ Direction/Mask/Compare	Clear digital IRQ status flag/read Port 0 direction, mask or compare register (dependent on BA + 3)	Clear digital chip/program Port 0 direction, mask or compare register (dependent on BA + 3)	BA + 2
Read Digital IRQ Status/ Set Digital Control Register	Read digital interrupt status word	Program digital control register	BA + 3

I/O Map 2: When Replacing Incremental Encoder Chip 2 with a 16 Bit Programmable Circuit:

Register Description	Read Function	Write Function	Address * (Decimal)
Digital I/O Port 2	Read Port 2 digital input lines	Program Port 2 digital output lines	BA + 4
Digital I/O Port 3	Read Port 3 digital input lines	Program Port 3 digital output lines	BA + 5
Port 2 Clear/ Direction/Mask/Compare	Clear digital IRQ status flag/read Port 2 direction, mask or compare register (dependent on BA + 7)	Clear digital chip/program Port 2 direction, mask or compare register (dependent on BA + 7)	BA + 6
Read Digital IRQ Status/ Set Digital Control Register	Read digital interrupt status word	Program digital control register	BA + 7

I/O Map 3: When Replacing Incremental Encoder Chip 3 with a 16 Bit Programmable Circuit:

Register Description	Read Function	Write Function	Address * (Decimal)
Digital I/O Port 4	Read Port 4 digital input lines	Program Port 4 digital output lines	BA + 8
Digital I/O Port 5	Read Port 5 digital input lines	Program Port 5 digital output lines	BA + 9
Port 4 Clear/ Direction/Mask/Compare	Clear digital IRQ status flag/read Port 4 direction, mask or compare register (dependent on BA + 11)	Clear digital chip/program Port 4 direction, mask or compare register (dependent on BA + 3)	BA + 10
Read Digital IRQ Status/ Set Digital Control Register	Read digital interrupt status word	Program digital control register	BA + 11

BA + 0, 4, 8: Digital I/O, Bit Programmable Port (Read/Write)

This port transfers the 8-bit Port 0, 2, or 4 bit programmable digital input/output data between the module and external devices. The bits are individually programmed as input or output by writing to the Direction Register at BA + 2, 6, or 10. For all bits set as inputs, a read reads the input values and a write is ignored. For all bits set as outputs, a read reads the last value sent out on the line and a write writes the current loaded value out to the line.

Note that when any reset of the digital circuitry is performed (clear chip or computer reset), all digital lines are reset to inputs and their corresponding output registers are cleared.

D7	D6	D5	D4	D3	D2	D1	D0
P0.7	P0.6	P0.5	P0.4	P0.3	P0.2	P0.1	P0.0
P2.7	P2.6	P2.5	P2.4	P2.3	P2.2	P2.1	P2.0
P4.7	P4.6	P4.5	P4.4	P4.3	P4.2	P4.1	P4.0

BA + 1, 5, 9: Digital I/O, Byte Programmable Port (Read/Write)

This port transfers the 8-bit Port 1, 3, or 5 digital input or digital output byte between the module and an external device. When set as inputs, a read reads the input values and a write is ignored. When set as outputs, a read reads the last value sent out of the port and a write writes the current loaded value out of the port.

Note that when any reset of the digital circuitry is performed (clear chip or computer reset), all digital lines are reset to inputs and their corresponding output registers are cleared.

D7	D6	D5	D4	D3	D2	D1	D0
I/O7	I/O6	I/O5	I/O4	I/O3	I/O2	I/O1	I/O0

BA + 2, 6, 10: Read/Program Port Direction/Mask/Compare Registers (Read/Write)

A read clears the IRQ status flag or provides the contents of one of digital I/O Port 0, 2, or 4's three control registers; and a write clears the digital chip or programs one of the three control registers, depending on the setting of bits 0 and 1 at BA + 3, 7, or 11. When bits 1 and 0 at BA + 3, 7, or 11 are 00, the read/write operations clear the digital IRQ status flag (read) and the digital chip (write). When these bits are set to any other value, one of the three Port 0, 2, or 4 registers is addressed.

Direction Register (BA + 3 (or 7 or 11), bits 1 and 0 = 01):

For all bits:
0 = input
1 = output

D7	D6	D5	D4	D3	D2	D1	D0
P0.7	P0.6	P0.5	P0.4	P0.3	P0.2	P0.1	P0.0

This register programs the direction, input or output, of each bit at Port 0, 2, or 4.

Mask Register (BA + 3 (or 7 or 11), bits 1 and 0 = 10):

For all bits:
0 = bit enabled
1 = bit masked

D7	D6	D5	D4	D3	D2	D1	D0
P0.7	P0.6	P0.5	P0.4	P0.3	P0.2	P0.1	P0.0

In the Advanced Digital Interrupt modes, this register is used to mask out specific bits when monitoring the bit pattern present at Port 0, 2, or 4 for interrupt generation. In normal operation where the Advanced Digital Interrupt feature is not being used, any bit which is masked by writing a 1 to that bit will not change state, regardless of the digital data written to the port. For example, if you set the state of bit 0 low and then mask this bit, the state will remain low, regardless of what you output (an output of 1 will not change the bit's state until the bit is unmasked).

Compare Register (BA + 3 (or 7 or 11), bits 1 and 0 = 11):

This register is used for the Advanced Digital Interrupt modes. In the match mode where an interrupt is generated when the Port 0, 2, or 4 bits match a loaded value, this register is used to load the bit pattern to be matched at the port. Bits can be selectively masked so that they are ignored when making a match. NOTE: Make sure that bit 3 at BA + 3, 7, or 11 is set to 1, selecting match mode, BEFORE writing the Compare Register value at this address. In the event mode where an interrupt is generated when any bit changes its current state, the value which caused the interrupt is latched at this register and can be read from it. Bits can be selectively masked using the Mask Register so a change of state is ignored on these lines in the event mode.

BA + 3, 7, 11: Read Digital I/O Status/Program Digital Mode (Read/Write)

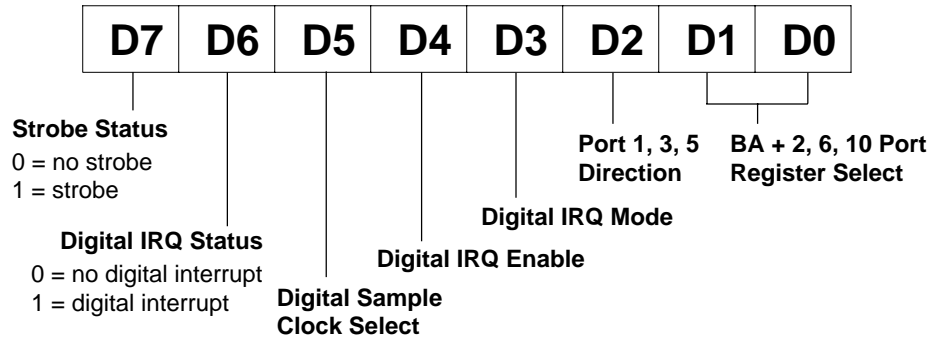

A read shows you whether a digital interrupt has occurred and lets you review the states of the other bits in this register. If bit 6 is high, then a digital interrupt has taken place. This provides the same status information as BA + 17, bits 0 through 2.

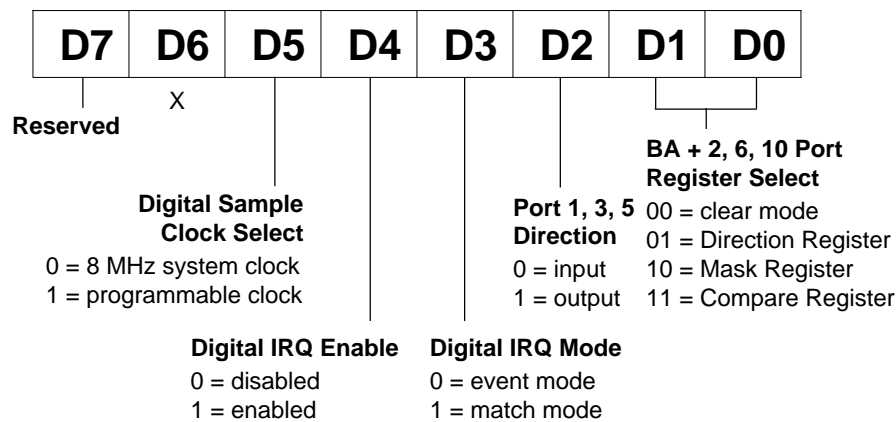

Digital Mode Register:

- Bits 0 and 1 – Select the clear mode initiated by a read/write operation at BA + 2, 6, or 10 or the Port 0, 2, or 4 control register you talk to at BA + 2, 6, or 10 (Direction, Mask, or Compare Register).
- Bit 2 – Sets the direction of the Port 1, 3, or 5 digital lines.
- Bit 3 – Selects the digital interrupt mode: event (any Port 0, 2, or 4 bit changes state) or match (Port 0, 2, or 4 lines match the value programmed into the Compare Register at BA + 2, 6, or 10).
- Bit 4 – Disables/enables digital interrupts. The IRQ channel is determined by the jumper setting on P4.
- Bit 5 – Sets the clock rate at which the digital lines are sampled when in a digital interrupt mode. Available clock sources are the 8 MHz system clock and the output of the 8254 Counter 1 (16-bit programmable clock). When a digital input line changes state, it must stay at the new state for two edges of the clock pulse (62.5 nanoseconds when using the 8 MHz clock) before it is recognized and before an interrupt can be generated. This feature eliminates noise glitches that can cause a false state change on an input line and generate an unwanted interrupt.
- Bit 6 – Read only (digital IRQ status).
- Bit 7 – Reserved.

Digital Interrupts

Each digital I/O chip that replaces an Incremental Encoder chip contains the digital I/O circuitry for two ports, or 16 bit programmable lines. One line on each digital I/O chip can be programmed as a digital interrupt by programming the IRQ select register with the digital line to be monitored, selecting an IRQ channel on P4, and setting the IRQ enable bit high in the Control Register.

If, for example, you wanted to use Port 0, bit 6 to generate an interrupt, you would select the desired IRQ channel on P4 and set bits 4, 1, and 0 at BA + 3 high to access the IRQ Source Register and enable digital interrupts. Then you would write 0110 in the bottom four bits at BA + 2 to select digital I/O line P0.6. Every time P0.6 goes from low to high (a positive going edge), an interrupt is generated.

Advanced Digital Interrupts - 8 Bit Programmable/8 Byte Programmable Only

When you have a digital I/O chip with 8 bit programmable and 8 byte programmable lines, each bit programmable digital I/O port supports two Advanced Digital Interrupt modes, event mode or match mode. These modes are used to monitor input lines for state changes. The mode is selected in the port's Control Register, bit 3 and enabled in the Control Register, bit 4.

Event Mode

When enabled, this mode samples the port's input lines at a specified clock rate (using the 8 MHz system clock or a programmable clock in the timer/counter programmed at bit 5 of the port's Digital Mode Register), looking for a change in state in any one of the eight bits. When a change of state occurs, an interrupt is generated and the input pattern is latched into the Compare Register. You can read the contents of this register to see which bit caused the interrupt to occur. Bits can be masked and their state changes ignored by programming the Mask Register.

Match Mode

When enabled, this mode samples the port's input lines at a specified clock rate (using the 8 MHz system clock or a programmable clock in the timer/counter programmed at bit 5 of the port's Digital Mode Register) and compares all input states to the value programmed in the Compare Register. When the states of all of the lines match the value in the Compare Register, an interrupt is generated. Bits can be masked and their states ignored by programming the Mask Register. NOTE: Make sure that the port's Digital IRQ Mode bit is set to 1, selecting match mode, BEFORE writing the Compare Register value for the port.

BA + 17: IRQ Status (Read Only)

When you have a mixture of Incremental Encoder circuits and digital I/O circuits on the module, a read at this address shows the status of the digital interrupt circuits, as well as the jumper-selectable interrupt circuit so that you can determine which circuit generated an interrupt. For bits 0 through 2, only the bits corresponding to digital I/O chips on the module are valid.

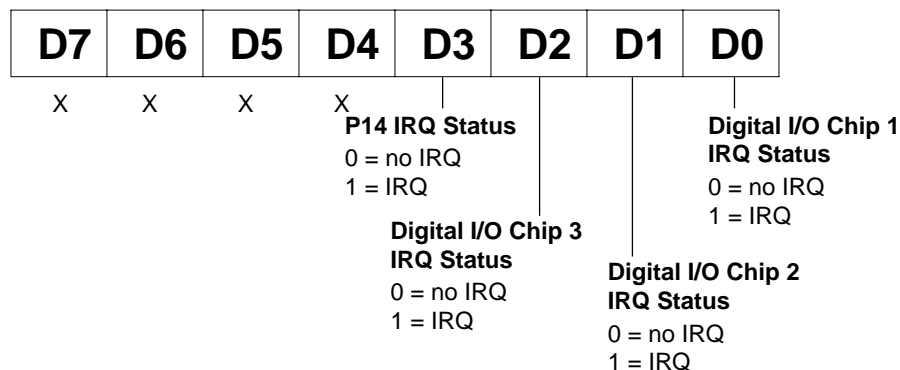

Sampling Digital Lines for Change of State

In the digital interrupt modes, the digital lines are sampled at a rate set by the 8 MHz system clock or the clock programmed in the timer/counter programmed at bit 5 of the port's Digital Mode Register. With each clock pulse, the digital circuitry looks at the state of the next bit. To provide noise rejection and prevent erroneous interrupt generation because of noise spikes on the digital lines, a change in the state of any bit must be seen for two edges of a clock pulse to be recognized by the circuit. Figure D-1 shows a diagram of this circuit.

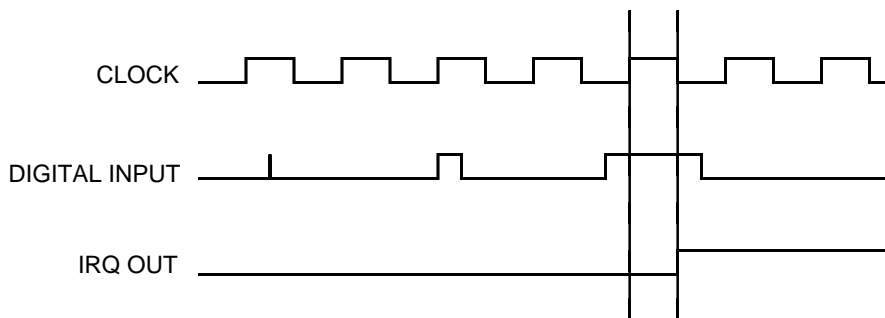

Fig. D-1 — Digital Interrupt Timing Diagram

Selecting the Interrupt Channel

The IRQ channel is selected by installing a jumper on header connector P4 across the desired pair of pins, as described in Chapter 1. A jumper is also installed across the G pins to activate the interrupt sharing feature. With this jumper installed, a jumper selectable interrupt source and digital interrupt sources can share the same interrupt channel without contention. This feature also allows multiple devices, such as another DM5814 module, to share the same interrupt channel.

To determine which interrupt source has generated an interrupt, you must check bits 0 through 3 of the status word read at BA + 17. Then service the interrupt that has occurred and clear the interrupt (the jumper selectable interrupt is cleared by reading BA + 16, and the digital interrupts are cleared by setting bits 1 and 0 in the corresponding port's Control Register and performing a read at the Direction/Mask/Compare Register address).

Resetting the Digital Circuitry

When a digital chip clear is issued, all of the digital I/O lines are set up as inputs and their corresponding output registers are cleared.

Strobing Data into Ports 0/1, 2/3, and 4/5

External data can be strobed into any digital I/O chip (Port 0/1, Port 2/3, and Port 4/5) by connecting the chip's strobe jumper on P13 and enabling the strobe by setting bit 3 high in the Control Register. The strobe input is the EXT INT1 signal, P2-2.

NOTE: DO NOT CONNECT a jumper on P13 for any Incremental Encoder circuit.

APPENDIX E

WARRANTY

LIMITED WARRANTY

Real Time Devices, Inc. warrants the hardware and software products it manufactures and produces to be free from defects in materials and workmanship for one year following the date of shipment from REAL TIME DEVICES. This warranty is limited to the original purchaser of product and is not transferable.

During the one year warranty period, REAL TIME DEVICES will repair or replace, at its option, any defective products or parts at no additional charge, provided that the product is returned, shipping prepaid, to REAL TIME DEVICES. All replaced parts and products become the property of REAL TIME DEVICES. **Before returning any product for repair, customers are required to contact the factory for an RMA number.**

THIS LIMITED WARRANTY DOES NOT EXTEND TO ANY PRODUCTS WHICH HAVE BEEN DAMAGED AS A RESULT OF ACCIDENT, MISUSE, ABUSE (such as: use of incorrect input voltages, improper or insufficient ventilation, failure to follow the operating instructions that are provided by REAL TIME DEVICES, "acts of God" or other contingencies beyond the control of REAL TIME DEVICES), OR AS A RESULT OF SERVICE OR MODIFICATION BY ANYONE OTHER THAN REAL TIME DEVICES. EXCEPT AS EXPRESSLY SET FORTH ABOVE, NO OTHER WARRANTIES ARE EXPRESSED OR IMPLIED, INCLUDING, BUT NOT LIMITED TO, ANY IMPLIED WARRANTIES OF MERCHANTABILITY AND FITNESS FOR A PARTICULAR PURPOSE, AND REAL TIME DEVICES EXPRESSLY DISCLAIMS ALL WARRANTIES NOT STATED HEREIN. ALL IMPLIED WARRANTIES, INCLUDING IMPLIED WARRANTIES FOR MERCHANTABILITY AND FITNESS FOR A PARTICULAR PURPOSE, ARE LIMITED TO THE DURATION OF THIS WARRANTY. IN THE EVENT THE PRODUCT IS NOT FREE FROM DEFECTS AS WARRANTED ABOVE, THE PURCHASER'S SOLE REMEDY SHALL BE REPAIR OR REPLACEMENT AS PROVIDED ABOVE. UNDER NO CIRCUMSTANCES WILL REAL TIME DEVICES BE LIABLE TO THE PURCHASER OR ANY USER FOR ANY DAMAGES, INCLUDING ANY INCIDENTAL OR CONSEQUENTIAL DAMAGES, EXPENSES, LOST PROFITS, LOST SAVINGS, OR OTHER DAMAGES ARISING OUT OF THE USE OR INABILITY TO USE THE PRODUCT.

SOME STATES DO NOT ALLOW THE EXCLUSION OR LIMITATION OF INCIDENTAL OR CONSEQUENTIAL DAMAGES FOR CONSUMER PRODUCTS, AND SOME STATES DO NOT ALLOW LIMITATIONS ON HOW LONG AN IMPLIED WARRANTY LASTS, SO THE ABOVE LIMITATIONS OR EXCLUSIONS MAY NOT APPLY TO YOU.

THIS WARRANTY GIVES YOU SPECIFIC LEGAL RIGHTS, AND YOU MAY ALSO HAVE OTHER RIGHTS WHICH VARY FROM STATE TO STATE.

DM5814 User Settings	
Base I/O Address:	
(hex)	(decimal)
IRQ Channel:	