

CML27686HX cpuModule™ User's Manual

RTD Enhanced Award BIOS Versions 4.51.xx

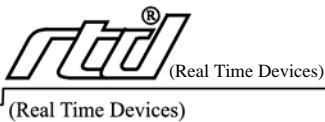

RTD Embedded Technologies, Inc.

"Accessing the Analog World"®

ISO9001 and AS9100 Certified

BDM-61000024
Rev. A

CML27686HX
cpuModule™
User's Manual



RTD Embedded Technologies, INC.
103 Innovation Blvd.
State College, PA 16803-0906

Phone: +1-814-234-8087
FAX: +1-814-234-5218

E-mail
sales@rtd.com
techsupport@rtd.com

web site
<http://www.rtd.com>

Revision History

Rev. A) Initial release for CML27686HX

Published by:

RTD Embedded Technologies, Inc.
103 Innovation Blvd.
State College, PA 16803-0906

Copyright 1999, 2002, 2003 by RTD Embedded Technologies, Inc.
All rights reserved
Printed in U.S.A.

The RTD Logo is a registered trademark of RTD Embedded Technologies. cpuModule and utilityModule are trademarks of RTD Embedded Technologies. PhoenixPICO and PheonixPICO BIOS are trademarks of Phoenix Technologies Ltd. PS/2, PC/XT, PC/AT and IBM are trademarks of International Business Machines Inc. MS-DOS, Windows, Windows 95, Windows 98 and Windows NT are trademarks of Microsoft Corp. PC/104 is a registered trademark of PC/104 Consortium. All other trademarks appearing in this document are the property of their respective owners.

Chapter 1: Introduction	7
The CML27686HX cpuModule	8
Specifications	10
Chapter 2: Getting Started	13
Basic Connector Locations	14
Fail safe boot ROM	16
Cable Kits	17
Connecting Power	18
Connecting the utility cable	19
Connecting a Keyboard	20
Connecting to the PC/104 Bus	21
Connecting to the PC/104-Plus PCI Bus	22
Default Configuration	24
Bootting to Boot Block Flash with Fail Safe Boot ROM	26
If You Misconfigure the cpuModule	27
For More Information	28
Chapter 3: Connecting the cpuModule	31
I/O Connections	32
Connector Locations	33
Auxiliary Power, CN3	35
Advanced Digital I/O Ports (aDIO), JP9 and JP10	37
Advanced Level 2 Digital I/O Port (a2DIO), CN19	38
Serial Port 1, CN7	39
Serial Port 2, CN8	42
Multifunction Connector, CN5	45
Bus Mouse Connector, CN4	47
USB Connector, CN17	48
PC/104 Bus, CN1 and CN2	49
PC/104-Plus PCI Bus, CN16	54
10/100 Base T and TX Connector CN18	57
Chapter 4: Configuring the cpuModule (BIOS Setup)	59
Entering the BIOS Setup	60
Default Configuration	61
Disabling Fail Safe Boot ROM	63
Installing SSD Memory	64
Quick Boot Description	65
Configuring with the RTD Enhanced Award BIOS	66
Chapter 5: Using the cpuModule	81
Memory Map	82
Input/Output Address Map	83
Hardware Interrupts	85
The RTD Enhanced Award BIOS	86
Power On Self Tests (POSTs)	87

RTD Enhanced Award BIOS POST Codes	90
Default Configuration	93
Direct Hardware Control	95
Advanced Digital I/O Ports (aDIO)	96
Basic Interrupt Information for Programmers:	100
Advanced Level 2 Digital I/O (a2DIO)	103
Watchdog Timer Control	116
Real Time Clock Control	117
Processor Clock Control	118
Storing Applications On-board	119
Ways to Use the Solid State Disk Socket	120
Using BIOS Extension Devices	121
Using Conventional Solid State Devices	122
Chapter 6: Hardware Reference	125
Jumpers	126
Jumpers and Default Jumper Settings	128
Mechanical Dimensions	129
686GX Processor Thermal Management	130
Chapter 7: Troubleshooting	131
Common Problems and Solutions	132
Troubleshooting a PC/104 System	135
How to Obtain Technical Support	136
How to Return a Product	137
Chapter 8: Limited Warranty	139

CHAPTER 1: INTRODUCTION

This manual is meant for users developing with the CML27686HX cpuModule. It contains information on hardware and software of the cpuModule.

READ THE SPECIFICATIONS FIRST.

The manual is organized as follows:

- Chapter 1: Introduction**
Introduces main features and specifications.
- Chapter 2: Getting Started**
Provides abbreviated instructions to get started.
- Chapter 3: Connecting the cpuModule**
Provides information on connecting the cpuModule to peripherals.
- Chapter 4: Configuring the cpuModule**
Provides information on configuring hardware and software.
- Chapter 5: Using the cpuModule**
Provides information needed to develop applications for the cpuModule. The chapter includes general information on the cpuModule, plus detailed information on storing applications and system functions, and using utility programs.
- Chapter 6: Hardware Reference**
Lists jumpers and their locations and mechanical dimensions.
- Chapter 7: Troubleshooting**
Offers advice on debugging problems with your system.
- Chapter 8: Warranty**

The CML27686HX cpuModule

The PC/104 cpuModules described in this manual are designed for industrial applications which require:

- software and hardware compatibility with the PC/AT world
- high-speed "number-crunching" operation
- low power consumption
- small physical dimensions
- high reliability
- good noise immunity

This cpuModule is highly integrated, combining all major functions of a PC/AT computer on one compact board. It integrates all primary I/O functions of a AT compatible computer:

- a keyboard interface
- two versatile RS232/422/485 serial ports
- a Real Time Clock
- a speaker port
- a PS/2 mouse port
- two USB ports
- One twisted pair 10/100 Base T and TX connection based on an Intel 82559ER PHY

It also enhances standard AT-compatible computer systems by adding:

- one Solid State Disk socket
- a non-volatile configuration without a battery
- a Watchdog Timer
- Fail Safe Boot ROM
- 16 bits of Advanced Digital I/O
- 8 bit Advanced Level 2 Digital I/O with Pulse Width Modulator and Incremental Encoder

The next figure shows a simplified block diagram of the cpuModule:

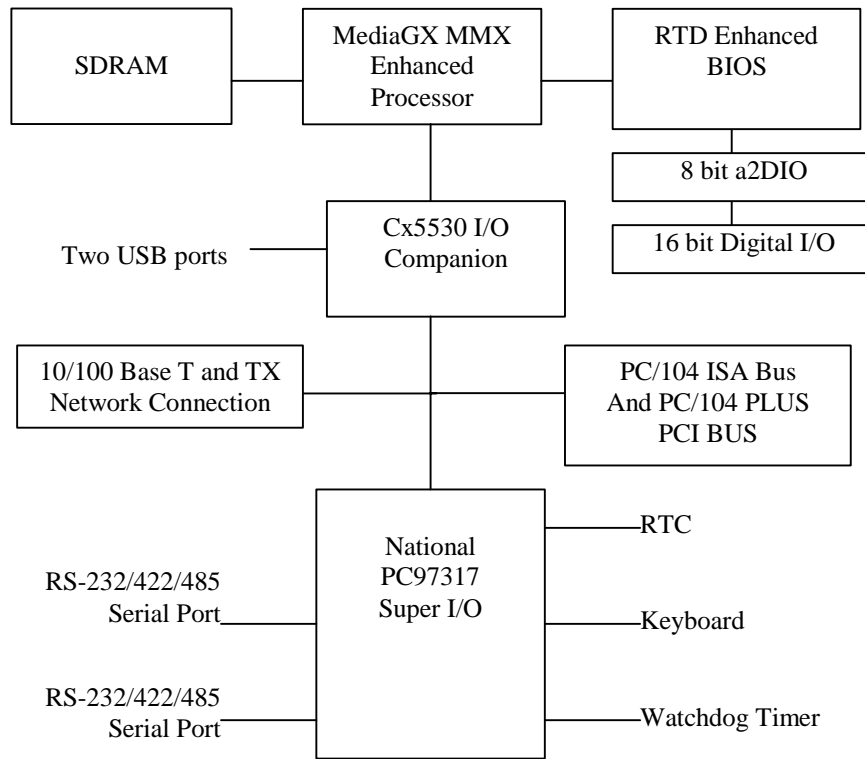

You can easily customize the cpuModule by stacking PC/104 modules such as modems, LAN controllers, or analog and digital data acquisition modules. Stacking PC/104 modules on the cpuModule avoids expensive installations of backplanes and card cages and preserves the module's compactness.

RTD Enhanced Award BIOS is also implemented in the cpuModule. This BIOS supports ROM-DOS™, MS-DOS and Windows operating systems. Drivers in the BIOS allow booting from floppy disk, hard disk, Solid State Disk, boot block flash, or DiskOnChip®, thus enabling the system to be used with traditional disk drives or non-mechanical drives.

The cpuModule and BIOS are also compatible with most real-time operating systems for PC compatible computers, although these may require creation of custom drivers to use the SSD and watchdog timer.

Specifications

CML27686HX300

- National Semiconductor Geode GX1 MMX enhanced microprocessor
- 300 MHz clock speed
- 2.0 V processor supply (provided on-board)
- 16 KB L1 cache
- Math coprocessor

CML27686HX333

- National Semiconductor Geode GX1 MMX enhanced microprocessor
- 333 MHz clock speed
- 2.2 V processor supply (provided on-board)
- 16 KB L1 cache
- Math coprocessor

DMA, Interrupts, Timers

- Six (6) DMA channels (8237 compatible)
- Fifteen (15) interrupt channels (8259 compatible)
- Three (3) counter/timers (8254 compatible)

USB ports

- 2 USB 1.0 ports

Advanced Digital I/O (aDIO)

- Two 8 bit, TTL compatible, programmable Digital I/O Ports.
- One port is bit direction programmable and the other is byte direction programmable.
- Advanced Interrupt modes
 - Interrupt on change
 - Interrupt on match
 - Interrupt on strobe

Advanced Level 2 Digital I/O (a2DIO)

- One 8 bit, TTL compatible, programmable Digital I/O Port.
- Bit direction programmable
- Advanced Interrupt modes
 - Interrupt on change
 - Interrupt on match
 - Interrupt on strobe
- 16 bit Pulse Width Modulator (PWM)
- Inverted and Non-Inverted Outputs
- 8 bit Incremental Encoder
 - Up to 16 MHz count rate
 - Software expandable
 - External Clear
 - Quadrature and Pulse-Count Modes

Memory Configurations

- 32MB
- 128MB

Fail-safe Boot ROM

- Surface mount Flash chip that holds ROM-DOS™
- Replaces the previous DiskOnChip®

Solid State Disk Socket

- SSD sockets can hold one of the following Conventional SSD devices.

Device	Full Read/Write Access	128Kbytes	256Kbytes	512Kbytes	1Mbyte
Atmel 5V Flash	yes	yes	yes	yes	no
SRAM	yes	yes	no	yes	no
NOVRAM	yes	yes	no	yes	no
EPROM	Read Only	yes	yes	yes	yes
AMD 5V Flash	Read Only	yes	no	yes	no

Device	Full Read/Write Access	Maximum Number per cpuModule	Sizes
DiskOnChip® 2000	yes	1	16MB - 1GB *
DiskOnChip® 1000	yes	1	1MB, 2MB
MCSI PromDisk	yes	1	4MB, 8MB *

(*) Larger devices may be available in the future.

Peripherals

- Two serial ports software configurable for RS232/422/485; baud rates from 50 to 115200 baud in 16450 and 16550A compatible mode and 1.5 Mbaud in Extended UART mode
- 16 bits of digital I/O
- 8 bits of a2DIO
- PC/AT standard keyboard port
- A PS/2 mouse port
- PC speaker port
- Real Time Clock (requires user-supplied external battery for date and time backup)
- Watchdog Timer with time-out of 1.2 seconds

BIOS

- RTD Enhanced Award BIOS
- Directly supports Solid State Disk (SSD) and M-Systems' DiskOnChip®
- User-configurable using built-in Setup program
- Nonvolatile configuration without a battery
- Can boot from floppy disk, hard disk, Solid State Disk, or fail-safe boot ROM

Connections

- AT bus, per PC/104 specifications (64-pin CN1, 40-pin CN2)
- Auxiliary Power Connector (12-pin CN3)
- PS/2 Mouse Connector (4-pin CN4)
- Multifunction connector (10-pin CN5)
- Serial port 1 connector (10-pin CN7)
- Serial port 2 connector (10-pin CN8)
- PCI bus, per PC/104-*Plus* specifications (120-pin CN16)
- Dual USB port connector(10-pin CN17)
- 10/100 Base T and TX connector(10-pin CN18)
- Two 8 bit Digital I/O Ports (two 12-pin JP9 JP10)
- One 8 bit a2DIO Port (10-pin CN19)

Physical Characteristics

- Dimensions: 4.25 x 3.775 x 0.6 inches (108.0 x 95.9 x 16mm)
- Weight (mass): 4.48 ounces (130 grams)
- PCB: 12-layer, mixed surface-mount and thru-hole

Operating environment

- Power supply: 5V +/- 5%, 10 Watts
- 686 GX1 processor operating temperature: -40 to +85 degrees C case (with proper cooling)
See 686GX *Processor Thermal Management*
- Operating relative humidity: 0 to 95%, non-condensing
- Storage temperature :-55 to +125 degrees C.

Power Consumption

Exact power consumption depends on the peripherals connected to the board, the selected SSD configuration and the memory configuration.

The table below lists power consumption for typical configurations and clock speeds:

Module	Consumption, typ.	RAM	SSD	Coprocessor
CML27686HX300 300 MHz	6.9 W	32 or 128 MB	None	Internal
CML27686HX333 333 MHz	7.1W	32 or 128 MB	None	Internal

CHAPTER 2: GETTING STARTED

For many users, the factory configuration of the cpuModule can be used to get a PC/104 system operational. If you are one of these users, you can get your system up and running quickly by following a few simple steps described in this chapter. Briefly, these steps are:

- Connect power.
- Connect the utility cable.
- Connect a keyboard.
- Default Bios Configuration
- Fail Safe Boot ROM

Refer to the remainder of this chapter for details on each of these steps.

Basic Connector Locations

The following figure(s) and table show the connectors used in this chapter

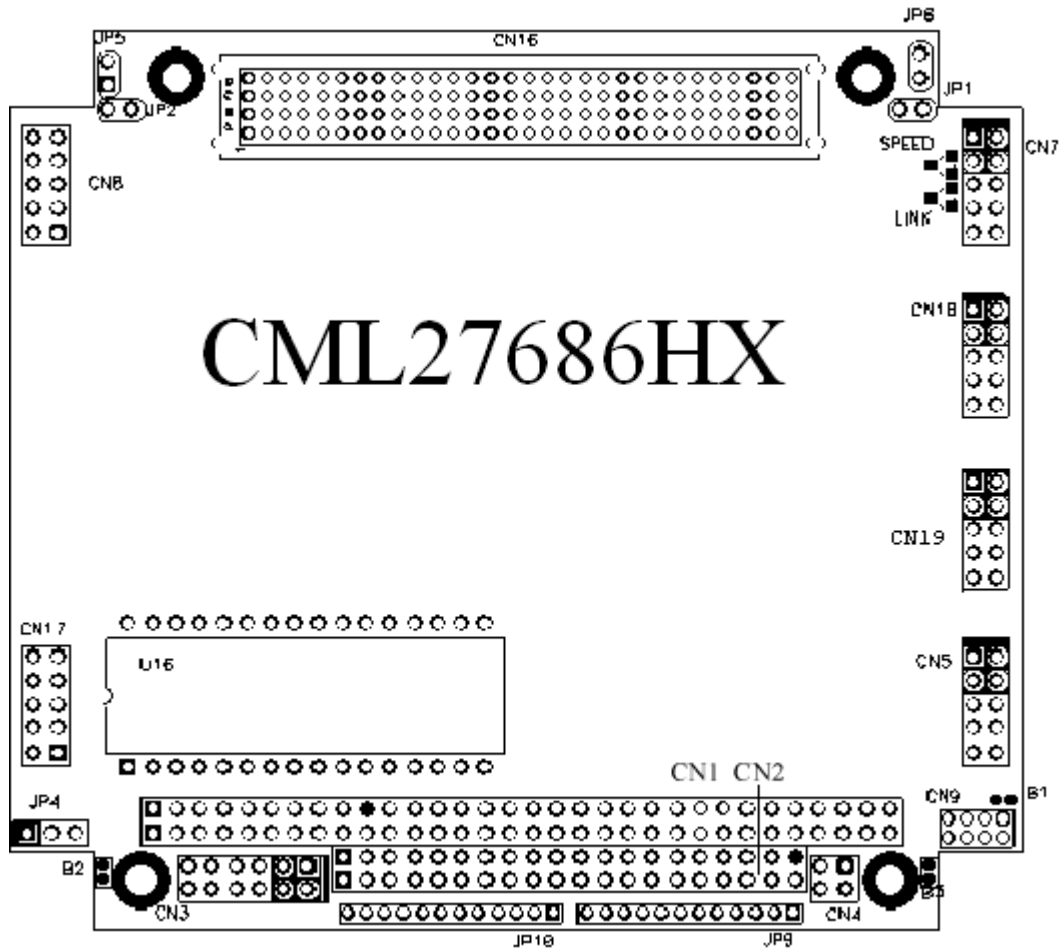

CML27686HX Basic Connector Locations

Connector	Function	Size
CN1	PC/104 Bus (XT)	64 pin
CN2	PC/104 bus (AT)	40 pin
CN3	Auxiliary power	12 pin
CN4	PS/2 Mouse	4 pin
CN5	Multifunction	10 pin
CN7	Serial Port1	10 pin
CN8	Serial Port2	10 pin
CN16	PCI Bus	120 pin
CN17	USB Connector	10 pin
CN18	10/100 Base T and TX	10 pin
CN19	a2DIO	10 pin
JP9 and JP10	Two 8 bit Digital I/O	two 12 pin

For a complete listing of connectors, please refer to *I/O Connections*.

NOTE!	Pin 1 of each connector is indicated by a square solder pad on the bottom of the PC board and a white square silkscreened on the top of the board.
--------------	--

Fail safe boot ROM

Fail Safe Boot ROM is supplied with the board. This feature is programmed into a surface mount flash chip. The programmed boot ROM is ROM-DOS™. Fail Safe Boot ROM allows the system to boot without any attached storage devices. i.e. floppy, IDE, SSD. Installing jumper JP5 will force the cpuModule to use fail safe boot ROM. This configuration allows you to boot to non-volatile onboard ROM-DOS™.

Cable Kits

For maximum flexibility, cables are not provided with the cpuModule. You may wish to purchase our cable kit for the cpuModule.

The XK-CM41 cable kit contains the following:

- Multifunction utility cable (keyboard socket, battery, reset, speaker)
- 10/100 base T and TX 10 Pin DIL TO RJ5
- Two serial port cables (DIL10 to DSUB9)
- Power cable (DIL12 to wire leads)
- Dual USB cable (4 Pin SIL to USB)
- PS/2 Mouse adapter (4 Pin DIL to PS/2 Female)

Connecting Power

WARNING!	If you improperly connect power, the module will almost certainly be <i>damaged</i> or <i>destroyed</i> . Such damage is not warranted! Please verify connections to the module <i>before</i> applying power.
-----------------	---

Power is normally supplied to the cpuModule through the PC/104 bus, connectors CN1 and CN2. If you are placing the cpuModule onto a PC/104 stack that has a power supply, you do not need to make additional connections to supply power.

If you are using the cpuModule without a PC/104 stack or with a stack that does not include a power supply, refer to ***Auxiliary Power, CN3*** for more details.

Connecting the utility cable

The Multifunction connector CN5, implements the following interfaces:

- AT keyboard
- Speaker output
- System reset input
- Battery input

To use these interfaces, you must connect to the Multifunction connector, making sure the orientation of pin 1 is correct. If you are using the Multifunction cable from our cable kit, the cable provides a small speaker, a 5-pin circular DIN connector for the keyboard, a push-button for resetting the PC/104 system, and a lithium battery to provide backup power to the Real Time Clock.

To connect individual devices to the Multifunction connector, please see ***Multifunction Connector, CN5***

Connecting a Keyboard

You may plug a PC/AT compatible keyboard directly into the circular DIN connector of the Multi-function cable in our cable kit.

NOTE!	<p>Some newer keyboards may use a smaller "mini-DIN" connector; you will need an adapter to plug these keyboards into the cpuModule. These connectors are available for order instead of the default circular DIN connector.</p> <p>Many keyboards are switchable between PC/XT and AT operating modes, with the mode usually selected by a switch on the back or bottom of the keyboard. For correct operation with this cpuModule, you must select AT mode.</p>
--------------	---

Connecting to the PC/104 Bus

The PC/104 bus connectors of the cpuModule are simply plugged onto a PC/104 stack to connect to other devices.

We recommend you follow the procedure below to ensure that stacking of the modules does not damage connectors or electronics.

WARNING!	Do not force the module onto the stack! Wiggling the module or applying too much pressure may damage it. If the module does not readily press into place, remove it, check for bent pins or out-of-place keying pins, and try again.
-----------------	--

- Turn off power to the PC/104 system or stack.
- Select and install standoffs to properly position the cpuModule on the PC/104 stack.
- Touch a grounded metal part of the rack to discharge any buildup of static electricity.
- Remove the cpuModule from its anti-static bag.
- Check that keying pins in the bus connector are properly positioned.
- Check the stacking order; make sure an XT bus card will not be placed between two AT bus cards or it will interrupt the AT bus signals.
- Hold the cpuModule by its edges and orient it so the bus connector pins line up with the matching connector on the stack.
- Gently and evenly press the cpuModule onto the PC/104 stack.

Connecting to the PC/104-Plus PCI Bus

The cpuModule is simply plugged onto a PC/104 stack. Other PC/104-Plus boards may then connect to the cpuModule's PC/104-Plus bus connector. Supplying power to the PCI bus is provided by the cpuModule.

We recommend you follow the procedure described for the PC/104 bus.

There are three additional considerations when using the PCI bus, PCI Bus signaling level, the slot selection switches on add in boards, and 3.3 volt power source for the expansion cards.

PCI Bus Signaling Levels

The PCI bus can operate at 3.3 or 5 volt signaling levels. This is controlled by solder blob jumper BL3 and is configured at the factory for 3.3 volts from on board. If you desire to use 5 volt signaling, because you are connecting cards to the bus that require 5 volt signaling, you have to change the solder blob jumper BL3 to position 2 and 3 instead of the default 1 and 2. Next supply 5 volts via the power connection CN3 or from the ISA bus. Pins 2 and 8 on the power connector are 5 volts.

WARNING!	The bus can only operate as 3.3 OR 5 volt signaling, not both. You will have to ensure that all your expansion card can operate together at a single signaling level. The CPU-module can supply a maximum of 2 Amps of current to the 3.3V supplies on the PCI bus.
-----------------	--

Slot Selection Switches

Unlike PC/104 cards, PC/104 Plus expansion cards have a "slot" selection switch or jumpers. In total, there are 4 PCI cards that can be stacked onto the cpuModule with switch positions 0 through 3. The distance from the CPU determines these switch settings. The card closest to the CPU is said to be in slot 0, the next closest slot 1 and so on to the final card as slot 3.

NOTE!	This requirement means that all PC/104 Plus cards must be stacked either on the top or the bottom of the CPU, not on both sides.
--------------	--

The "slot" setting method may vary from manufacturer to manufacturer, but the concept is the same. The CPU is designed to provide the correct delay to the clock signals to compensate for the bus length. The correct switch setting ensures the proper clock delay setting, interrupt assignment, and bus grant/request channel assignment. Refer to the expansion board's manual for the proper settings. Each expansion card must be in a different slot.

PCI Bus Expansion Card Power

+5 Volt DC

The +5 volt power pins on the PC/104 Plus PCI bus are directly connected to the +5 volt pins on the PC/104 connector and the power connector CN3 (pins 2 and 8). +5 volt expansion boards can be powered directly from these pins.

+3.3 Volt DC

The default source for the +3.3 volt power pins on the PC/104 Plus PCI bus is an on board power converter. The on-board +5 volt to +3.3 volt converter is capable of supplying a maximum of 2 amps of 3.3 volts to the PCI bus. If 2 amps is not enough change solder blob BL1 from 1 and 2 to 2 and 3 . This change will connect the 3.3 volt power pins on the PCI bus to pins 10 and 12 on power connector . This change will allow a new power source, connected to the power connector , to drive the 3.3 volt power pins on the PCI bus.

Booting the cpuModule for the First Time

You can now apply power to the cpuModule. You will see:

- the cpuModule BIOS version information
- a message requesting you press {Del} to enter the Setup program

If you don't press {Del}, the cpuModule will try to boot from the current settings.

If you press {Del}, the cpuModule will enter Setup. Once you have configured the cpuModule using Setup, save your changes and reboot.

NOTE!	By default, boards are shipped with fail safe boot ROM enable. When Fail Safe Boot ROM is enabled the system will boot to it exclusively.
--------------	--

Default Configuration

In addition to the Setup configuration stored on the board, the cpuModule has a permanent default configuration. The system will resort to using this default if an error occurs when accessing the EPROM which holds the Setup on the module.

The default configuration is listed below.

BIOS Default Configuration	
Function	Default selection
IDE Interface 0 Master	Auto detect
IDE Interface 0 Slave	Auto detect
IDE Interface 1 Master	Auto detect
IDE Interface 1 Slave	Auto detect
Boot device	Floppy then hard disk
BIOS Extension	Disabled
Floppy Drive 1	3.5" 1.44 Meg
Floppy Drive 2	not installed
Serial port 1	RS232 at 3F8H
Serial port 2	RS232 at 2F8H
Keyboard	Enabled if connected
USB	Enable if connected
Fail safe boot ROM	Enabled
Select Active Video	
Power Management	Disabled
PNP OS Installed	No
Resources Controlled By	Auto
PCI IRQ Activated By	Level
IDE HDD Block Mode	Enabled
KBC Input Clock	8 Mhz
SSD Window	D800:0000
Halt On	No Errors
Virus Warning	Disabled
CPU Internal Cache	Enabled
Cyrix 6X86/MII CPUID	Enabled
Swap Floppy Drive	Disabled
Boot Up Numlock Status	Off
Gate A20 Option	Fast
Security Option	Setup
Report No FDD for WIN95	Yes
Quick Boot	Disabled
Extended Memory Test	Disabled
ISA Plug-n-Play Support	Enabled
Video Bios Shadow	Enabled

C8000-DFFFF	Disabled
16-bit I/O Recovery (Clock)	5
8-bit I/O Recovery (Clock)	5
Ethernet	Enabled
a2DIO	Disabled
Digital I/O IRQ	IRQ5

Booting to Boot Block Flash with Fail Safe Boot ROM

The Fail Safe Boot ROM is a special build of ROM-DOS™ located inside a surface mounted Boot Block Flash chip that is memory mapped to the SSD window. Boot Block Flash is a write protected flash device that contains the BIOS and extra room where the Fail Safe Boot ROM is stored in the ROM DISK. The build is special because it can understand the ROM DISK format on the flash chip. Additionally, Fail Safe Boot ROM is an emergency interface accessible by an external computer. The ROM DISK contains REMDISK and REMSERVE for remote access to the system's disk drives. Due to the size of the flash chip, Fail Safe Boot ROM contains an abbreviated selection of the ROM-DOS™ utilities, however, the complete ROM-DOS™ is contained on a CD shipped with the board.

The purpose of the Fail Safe Boot ROM is to make the board bootable when the customer receives the cpuModule. Fail Safe Boot ROM can be used as an indicator of the board's functionality when booting problems arise with another operating system. This test can be accomplished by installing JP5. Installing JP5 forces the cpuModule to boot to Fail Safe Boot ROM. The ROM DISK that contains the Fail Safe Boot ROM acts as an example of what can be programmed into the flash chip. Last, Fail Safe Boot ROM allows files to be transferred on or off the storage devices in the system by use of REMSERV and REMDISK, two ROM-DOS™ utilities.

If the user would need remote access to the system run REMSERV on the target system and REMDISK on the host system. The end result would be that the storage devices on the target system would appear as additional drives on the host system. Information could then be transferred between hard disks by using a standard NULL Modem cable over a serial port. REMSERV makes the connection appear as an additional drive to the user. For details concerning this type of access, please refer to the ROM-DOS™ user's guide shipped with your board

NOTE!	By default, boards are shipped with fail safe boot ROM enable. When Fail Safe Boot ROM is enabled the system will boot to it exclusively.
--------------	--

The first time, your system will boot to the DOS prompt at the first available drive letter. If you do not intend to use REMSERV or REMDISK or you intend to boot from another device, you will need to disable Fail Safe Boot ROM. See the steps below for the method to disable it.

- Reset the system by either shutting it off and turning it on or by using the reset button.
- while the system is booting repeatedly press the DEL key to enter the BIOS setup.
- Choose INTEGRATED PERIPHERALS using the arrow keys and enter.
- Once in INTEGRATED PERIPHERALS set Fail Safe Boot in SSD Win: Disabled

If You Misconfigure the cpuModule

It is possible that you may incorrectly configure the cpuModule using Setup. If this happens the correct procedure is:

- Start Re-booting the cpuModule.
- While the system is re-booting repeatedly press the {Del} key until the cpuModule enters Setup.
- Change the parameters to correctly match your system.

If the above fails:

- Insert jumper JP5. This will force the cpuModule to boot using fail safe boot ROM.
- Boot the cpuModule.
- Press the {delete} key to enter Setup.

For More Information

This chapter has been intended to get the typical user up and running quickly. If you need more details, please refer to the following chapters for more information on configuring and using the cpu-Module.

Phone: 814-234-8087

Fax: 814-234-5218

RTD Embedded Technologies, Inc.

103 Innovation Blvd.

State College PA 16803-0906

USA

Our website: www.rtd.com

Our e-mail: techsupport@rtd.com

CHAPTER 3: CONNECTING THE CPU MODULE

This chapter contains necessary information for any of the connectors on the cpuModule.

I/O Connections

The cpuModule comes from the factory ready to connect to the peripherals shown in the following table.

Default Peripheral Settings

Item	Setting	Controlled by
Boot device	Floppy / DOC	Setup
SSD Power	5V on board or battery	Jumper
Serial Port #1	RS232 at 3F8H, IRQ 4	Setup
Serial Port #2	RS232 at 2F8H, IRQ 3	Setup
USB Ports #1 and #2	Enabled	Setup
Floppy Drive 1	1.44M 3.5"	Setup
10/100 Base T and TX Ethernet	Enabled	Setup
Digital I/O	I/O Base at 450H	Hardware
a2DIO	Disabled	Setup
Floppy Drive 2	Not installed	Setup
All IDE Drives	Auto Detect	Setup

If you are using peripherals compatible with this list, you do not need to configure any jumpers or software settings before connecting them. If you are using different peripherals, you may need to change the cpuModule settings. In that case, please see *Configuring with the RTD Enhanced Award BIOS*.

Connector Locations

The figure and table below show all connectors and the SSD socket of the cpuModule.

CML27686HX Connector Locations

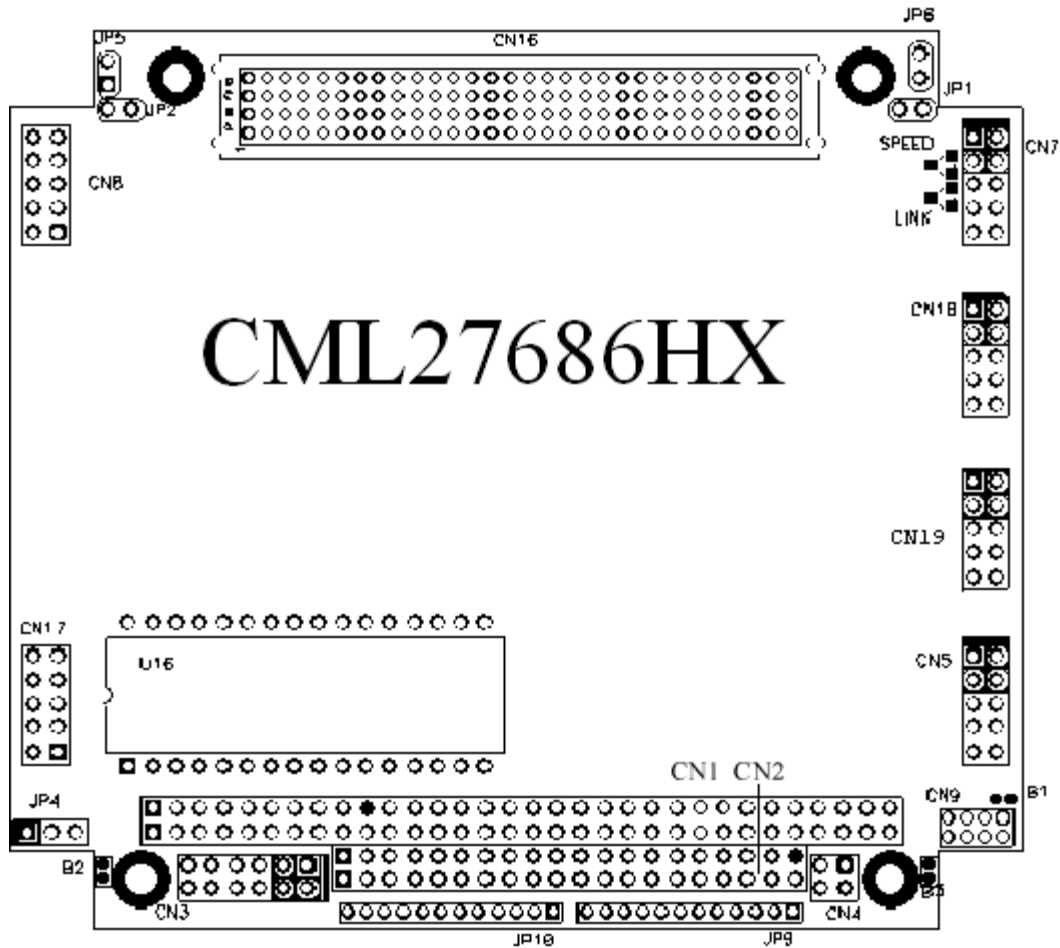

NOTE!

Pin 1 of each connector is indicated by a square solder pad on the bottom of the PC board and a white box silkscreened on the top of the board.

Connector	Function	Size
CN1	PC/104 XT Bus	64 Pin
CN2	PC/104 AT Bus	40 Pin
CN3	Auxiliary Power	12 pin
CN4	Bus Mouse	4 pin
CN5	Multifunction	10 pin
CN7	Serial port 1	10 pin
CN8	Serial port 2	10 pin
CN16	PCI BUS	120 pin
CN17	2 USB ports	10 pin
CN18	10/100 Base T and TX	10 pin
CN19	a2DIO	10 pin
JP9 and JP10	Two 8 bit Digital I/O	two 12 pin

Auxiliary Power, CN3

WARNING!	If you improperly connect power, the module will almost certainly be <i>destroyed</i> . Please verify power connections to the module <i>before</i> applying power.
-----------------	---

The power supply can be conveyed to the module either through the PC/104 bus (CN1 and CN2) or through the Auxiliary Power Connector, CN3. The cpuModule only uses +5 VDC and ground. +12 VDC, -12 VDC and -5 VDC may be required on other PC/104 boards in the system.

Auxiliary Power Connector CN3

Pin	Signal	Function
1	GND	Ground
2	+5 V	+5 Volts DC
3	N/C	Not Connected
4	+12 V	+12 Volts DC
5	-5 V	-5 Volts DC
6	-12 V	-12 Volts DC
7	GND	Ground
8	+5 V	+5 Volts DC
9	GND	Ground
10	+3.3 V	See Note
11	CPU V+	See Note
12	+3.3 V	See Note

Insufficient current supply will prevent your cpuModule from booting. The gauge and length of the wire used for connecting power to the cpuModule must be taken into consideration. Some power connectors have clip leads on them and may have significant resistance. Make sure that the input voltage does not drop below 4.8V at the 5V power pins (see the table labeled Typical Power Consumption for the cpuModule's power requirements). A good rule of thumb is to use wire that can supply twice the power your system requires.

NOTE!	Connect two separate wires to the +5V pins (2 and 8) on the power connector to ensure a good power supply. We recommend that no less than 22 gauge wire be used and the length of this wire should not exceed 3 ft. Always measure the voltage drop from your power supply to the power pins on the cpuModule. The voltage at pins (2 and 8) should be +5V.
--------------	---

Facing the connector pins, the pinout of the Auxiliary Power connector is:

11	9	7	5	3	1
CPU V+	GND	GND	-5V	N/C	GND
3.3 V	3.3 V	+5V	-12V	+12V	+5V
12	10	8	6	4	2

NOTES!	<p>-5 VDC, +12 VDC and -12 VDC voltages are not used by the module, but are connected to the PC/104 bus connectors CN1 and CN2.</p> <p>The 3.3 volt pins (10 and 12) on power connector CN3 can be used to monitor the onboard 3.3 voltage regulator. In effect, these pins (10 and 12) become outputs. Don't use these pins as a source of 3.3 volts to another board and don't connect these pins to a 3.3 volt power supply.</p> <p>The CPU V+ pin 11 of CN3 is used to monitor the onboard CPU regulator which is 2.0 volts. Don't use this as source of 2.0 volts and don't connect this pin to a 2.0 volt power supply.</p> <p>Pins 10 and 12 on CN3 are floating by default factory setting. These pins are not set up for monitoring or power. If monitoring is needed at these pins, please contact us for details.</p>
---------------	--

Power Supply Protection

The cpuModule has protection circuitry which helps prevent damage due to problems with the +5V supply, such as:

- Reversed polarity
- Overvoltage

Advanced Digital I/O Ports (aDIO), JP9 and JP10

Pin 1 is indicated by a square solder pad on the pin. This connector is located on the edge of the cpuModule along the PC/104 bus.

JP10 Digital I/O Port 0 Connector Pinout

JP10 Pin	Function
1	GND
2	P0-0
3	P0-1
4	P0-2
5	P0-3
6	P0-4
7	P0-5
8	P0-6
9	P0-7
10	strobe0
11	5 VOLTS
12	GND

JP9 Digital I/O Port 1 Connector Pinout

JP9 Pin	Function
1	GND
2	P1-0
3	P1-1
4	P1-2
5	P1-3
6	P1-4
7	P1-5
8	P1-6
9	P1-7
10	strobe1
11	5 VOLTS
12	GND

Advanced Level 2 Digital I/O Port (a2DIO), CN19

The a2DIO port is on CN19. This port provides eight bits of digital input and output. The direction of each bit is individually programmable. Alternate functions, such as pulse width modulation and incremental encoder are also available under software selection. For a detailed description of how to use the a2DIO, please see the a2DIO section of the **Using the cpuModule** chapter. The connector pinout is shown below.

Connector CN19

Pin	Signal	Function	in/out
1	a2D0	Digital I/O	in/out
2	a2D1	Digital I/O	in/out
3	a2D2	Digital I/O	in/out
4	a2D3	Digital I/O	in/out
5	a2D4	Digital I/O	in/out
6	a2D5	Digital I/O	in/out
7	a2D6	Digital I/O	in/out
8	a2D7	Digital I/O	in/out
9	GND	Signal Ground	--
10	a2STR	Strobe (Clock)	in

Pin one of the a2DIO connector is indicated by a square pin on the board, and a block of white silk-screen. Facing the a2DIO port's connector pins, the pinout is:

9	7	5	3	1
GND	a2D6	a2D4	a2D2	a2D0
a2STR	a2D7	a2D5	a2D3	a2D1
10	8	6	4	2

Serial Port 1, CN7

The first serial port is implemented on connector CN7. It is normally configured as a PC compatible full-duplex RS232 port, but you may use the Setup program to re-configure it as half-duplex RS422 or full-duplex RS422 or RS485. The I/O address and corresponding interrupt must also be selected using Setup. The available I/O addresses and the corresponding interrupts are shown in the following table

First Serial Port Settings	
I/O Address	IRQ
03F8H	IRQ4
02F8H	IRQ3
03E8H	IRQ4
02E8H	IRQ3

First Serial Port UART

The first serial port is implemented with a 16550-compatible UART (Universal Asynchronous Receiver/Transmitter). This UART is capable of baud rates up to 115.2 kbaud in 16450 and 16550A compatible mode and 1.5 Mbaud in Enhanced UART mode, and includes a 16-byte FIFO. Please refer to any standard PC-AT hardware reference for the register map of the UART.

RS232 Serial Port (Default)

The full-duplex RS232 mode is the default setting on the cpuModule. With this mode enabled, connector CN7 must be connected to RS232 compatible devices. The following table gives the connector pinout and shows how to connect to an external serial connector, either DB25 or DB9 compatible.

Connector CN7 in RS-232 Mode

Pin	Signal	Function	in/out	DB25	DB9
1	DCD	Data Carrier Detect	in	8	1
2	DSR	Data Set Ready	in	6	6
3	RXD	Receive Data	in	3	2
4	RTS	Request To Send	out	4	7
5	TXD	Transmit data	out	2	3
6	CTS	Clear To Send	in	5	8
7	DTR	Data Terminal Ready	out	20	4
8	RI	Ring Indicate	in	22	9
9,10	GND	Signal Ground	--	7	5

Facing the serial port's connector pins, the pinout is:

9	7	5	3	1
GND	DTR	TXD	RXD	DCD
GND	RI	CTS	RTS	DSR
10	8	6	4	2

RS422 or RS485 Serial Port

You may use Setup to configure the first serial port as RS422 or RS485. In this case, you must connect the serial port to an RS422 or RS485 compatible device.

When using RS422 or RS485 mode, you can use the port in either half-duplex (two-wire) or full-duplex (four-wire) configurations. For half-duplex (2-wire) operation, you must connect RXD+ to TXD+, and connect RXD- to TXD-.

NOTE!	<p>A 120 ohm termination resistors is provided on the cpuModule. Termination is usually necessary on all RS422 receivers and at the ends of the RS485 bus.</p> <p>If the termination resistor is required, it can be enabled by closing jumper JP1.</p>
--------------	---

When using full-duplex (typically in 422 mode) connect the ports as shown in the table below.

Full-Duplex Connections

Port 1	Port 2
RXD+	TXD+
TXD+	RXD+
RXD-	TXD-
TXD-	RXD-

When using half-duplex in 485 connect the ports as shown in the table below.

Half-Duplex 485 Mode

From	To
Port 1 TXD+	Port 1 RXD+
Port 1 TXD-	Port 1 RXD-
Port 1 TXD+	Port 2 RXD+
Port 1 RXD-	Port 2 TXD-

RS422 and RS485 Mode Pinout

The following table gives the pinout of the serial port connector when RS422 or RS485 modes are enabled.

Connector CN7 in RS-422/485 Mode

Pin	Signal	Function	in/out	DB9
1	--	Data Carrier Detect	--	1
2	--	Data Set Ready	--	6
3	RXD-	Receive Data (-)	in	2
4	TXD+	Transmit Data (+)	out	7
5	TXD-	Transmit Data (-)	out	3
6	RXD+	Receive Data (+)	in	8
7	--	Reserved	--	4
8	--	Reserved	--	9
9,10	gnd	Signal ground	out	5

Facing the serial port connector, the pinout is:

9	7	5	3	1
GND	Rsvd	TXD-	RXD-	Rsvd
GND	Rsvd	RXD+	TXD+	Rsvd
10	8	6	4	2

NOTE!

when using RS422 or RS485 Mode

When using the serial port in RS422 or RS485 mode, the serial transmitters are enabled and disabled under software control.

The transmitters are enabled by manipulating the Request To Send (RTS*) signal of the first serial port controller. This signal is controlled by writing bit 1 of the Modem Control Register (MCR) as follows:

- If MCR bit 1 = 1, then RTS* = 0, and serial transmitters are disabled
- If MCR bit 1 = 0, then RTS* = 1, and serial transmitters are enabled

For more information on the serial port registers, including the MCR, please refer to a standard PC-AT hardware reference for the 16550-type UART.

Serial Port 2, CN8

The second serial port is implemented on connector CN8. It is normally configured as a PC compatible full-duplex RS232 port, but you may use the Setup program to re-configure it as half- or full-duplex RS422 or RS485. The I/O address and corresponding interrupt must also be selected using Setup. The available I/O addresses and the corresponding interrupts are shown in the following table

Second Serial Port Settings	
I/O Address	Default IRQ
03F8H	IRQ4
02F8H	IRQ3
03E8H	IRQ4
02E8H	IRQ3

Second Serial Port UART

The second serial port is implemented with a 16550-compatible UART (Universal Asynchronous Receiver/Transmitter). This UART is capable of baud rates up to 115.2 kbaud in 16450 and 16550A compatible mode and 1.5 Mbaud in Enhanced UART mode, and includes a 16-byte FIFO. Please refer to any standard PC-AT hardware reference for the register map of the UART.

RS232 Serial Port (Default)

The full-duplex RS232 mode is the default setting on the cpuModule. With this mode enabled, the serial port connector must be connected to RS232 compatible devices. The following table gives the connector pinout and shows how to connect to an external serial connector, either XT (DB25) or AT(DB9) compatible.

Facing the serial connector pins, the pinout is:

9	7	5	3	1
GND	DTR	TXD	RXD	DCD
GND	RI	CTS	RTS	DSR
10	8	6	4	2

The following table gives the pinout of the serial port connector when RS232 mode is enabled.

Connector CN8 in RS-232 Mode

Pin	Signal	Function	in/out	DB25
1	DCD	Data Carrier Detect	in	8
2	DSR	Data Set Ready	in	6
3	RXD	Receive Data	in	3
4	RTS	Request To Send	out	4
5	TXD	Transmit data	out	2
6	CTS	Clear To Send	in	5
7	DTR	Data Terminal Ready	out	20
8	RI	Ring Indicate	in	22
9,10	GND	Signal Ground	--	7

RS422 or RS485 Serial Port

You may use Setup to configure the second serial port as RS422 or RS485. In this case, you must connect the serial port to an RS422 or RS485 compatible device.

When using RS422 or RS485 mode, you can use the port in either half-duplex (two-wire) or full-duplex (four-wire) configurations. For half-duplex (2-wire) operation, you must connect RXD+ to TXD+, and connect RXD- to TXD-.

NOTE!	<p>A 120 ohm termination resistors is provided on the cpuModule. Termination is usually necessary on all RS422 receivers and at the ends of the RS485 bus.</p> <p>If the termination resistor is required, it can be enabled by closing jumper JP2.</p>
--------------	---

When using full-duplex (typically in 422 mode) connect the ports as shown in the table below.

Full-Duplex Connections

Port 1	Port 2
RXD+	TXD+
TXD+	RXD+
RXD-	TXD-
TXD-	RXD-

When using half-duplex in 485 connect the ports as shown in the table below.

Half-Duplex 485 Mode

From	To
Port 1 TXD+	Port 1 RXD+
Port 1 TXD-	Port 1 RXD-
Port 1 TXD+	Port 2 RXD+
Port 1 RXD-	Port 2 TXD-

The following table gives the pinout of connector CN8 when RS422 or RS485 modes are enabled.

Connector CN8 in RS-422/485 Mode

Pin	Signal	Function	in/out	DB9
1	--	Data Carrier Detect	--	1
2	--	Data Set Ready	--	6
3	RXD-	Receive Data (-)	in	2
4	TXD+	Transmit Data (+)	out	7
5	TXD-	Transmit Data (-)	out	3
6	RXD+	Receive Data (+)	in	8
7	--	Reserved	--	4
8	--	Reserved	--	9
9,10	gnd	Signal ground	out	5

Facing the serial port's connector pins, the pinout is:

9	7	5	3	1
GND	Rsvd	TXD-	RXD-	Rsvd
GND	Rsvd	RXD+	TXD+	Rsvd
10	8	6	4	2

NOTE!

when using RS422 or RS485 Mode

When using the serial port in RS422 or RS485 mode, the serial transmitters are enabled and disabled under software control. The transmitters are enabled by manipulating the Request To Send (RTS*) signal of the first serial port controller or by I/O port 0x18. This signal is controlled by writing bit 1 of the Modem Control Register (MCR) or writing to I/O port 0x18 as follows:

- If MCR bit 1 = 1, then RTS* = 0, and serial transmitters are disabled
- If MCR bit 1 = 0, then RTS* = 1, and serial transmitters are enabled
- If Port 0x18h OR 0xCh then transmitters always on
- If Port 0x18h AND 0x3h then transmitters under RTS* control

For more information on the serial port registers, including the MCR, please refer to a standard PC-AT hardware reference for the 16550-type UART.

Multifunction Connector, CN5

The Multifunction connector implements the following functions:

- Speaker output
- AT keyboard
- System reset input
- Battery Input

The following table gives the pinout of the Multifunction connector.

Multifunction Connector CN5

Pin	Signal	Function	in/out
1	SPKR+	Speaker output (open collector)	out
2	SPKR-	Speaker output (+5 volts)	out
3	RESET	Manual push button reset	in
4	--	Not connected	--
5	KBD	Keyboard Data	in
6	KBC	Keyboard Clock	out
7	GND	Ground	--
8	KBP	Keyboard Power (+5 volts)	out
9	BAT	Battery input	in
10	--	Not Connected	--

Facing the connector pins, the pinout is:

9	7	5	3	1
BAT	GND	KBD	RESET	SPKR+
	KBP	KBC		SPKR-
10	8	6	4	2

Speaker

A speaker output is available on pins 1 and 2 of the Multifunction connector. These outputs are controlled by a transistor to supply 0.1 watt of power to an external speaker. The external speaker should have 8 ohm impedance and be connected between pins 1 and 2.

Keyboard

An AT compatible keyboard can be connected to the Multifunction connector. Usually PC keyboards come with a cable ending with a 5-pin male 'DIN' connector. The following table lists the relationship between the Multifunction connector pins and a standard 'DIN' keyboard connector.

Keyboard Connector Pins on CN5			
Pin	Signal	Function	DIN
5	KBD	Keyboard Data	2
6	KBC	Keyboard Clock	1
7	GND	Ground	4
8	KBP	Keyboard Power (+5 Volts)	5

To ensure correct operation, check that the keyboard is either an AT compatible keyboard or a switchable XT/AT keyboard set to AT mode. Switchable keyboards are usually set by a switch on the back or bottom of the keyboard.

System Reset

Pin 3 of the multifunction connector allows connection of an external push-button to manually reset the system. The push-button should be normally open, and connect to ground when pushed.

Battery

Pin 9 of the multifunction connector is the connection for an external backup battery (in the range 2.40 V to 4.15 V; typically 3.0 or 3.6 V). This battery is used by the cpuModule when system power is removed, to preserve the date and time in the Real Time Clock and preserve SRAM contents if the SSD jumpers are configured for battery backup.

Bus Mouse Connector, CN4

The following table gives the pinout of the Bus Mouse connector.

Bus Mouse Connector, CN4

Pin	Signal	Function	in/out
1	+5 V	+5 Volts	out
2	GND	Ground	out
3	MCLK	Mouse Clock	out
4	MDAT	Mouse Data	bidirectional

Facing the connector pins, the pinout is:

3	1
MCLK	+5 V
MDAT	GND
4	2

USB Connector, CN17

Two USB 1.0 compliant ports are available on CN17. The following table gives the pinout of the USB connector.

Table 1: USB Connector, CN17

9 PIN D Pin	10 PIN DIL Pin	Signal	Function	in/out
1	1	VCC1	Supply 5V to USB1	out
6	2	VCC2	Supply 5V to USB2	out
2	3	DATA1-	Bi-directional data line for USB1	in/out
7	4	DATA2-	Bi-directional data line for USB2	in/out
3	5	DATA1+	Bi-directional data line for USB1	in/out
8	6	DATA2+	Bi-directional data line for USB2	in/out
4	7	GRND	Signal Ground	out
9	8	GRND	Signal Ground	out
5	9	GRND	Signal Ground	out
--	10	GRND	Signal Ground	out

Facing the connector pins, the pinout is

9	7	5	3	1
GRND	GRND	DATA1+	DATA1-	VCC1
GRND	GRND	DATA2+	DATA2-	VCC2
10	8	6	4	2

PC/104 Bus, CN1 and CN2

Connectors CN1 and CN2 carry signals of the PC/104 bus; these signals match definitions of the IEEE P996 standard. The following tables list the pinouts of the PC/104 bus connectors.

The following table lists the signals of the XT portion of the PC/104 bus (see Notes below AT Bus table).

PC/104 XT Bus Connector, CN1

Pin	Row A	Row B
1	N.C.	0V
2	SD7	RESETDRV
3	SD6	+5V
4	SD5	IRQ2
5	SD4	-5V
6	SD3	DRQ2
7	SD2	-12V
8	SD1	N.C.
9	SD0	+12V
10	IOCHRDY	(Keying pin)
11	AEN	SMEMW*
12	SA19	SMEMR*
13	SA18	IOW*
14	SA17	IOR*
15	SA16	DACK3*
16	SA15	DRQ3
17	SA14	DACK1*
18	SA13	DRQ1
19	SA12	REFRESH*
20	SA11	SYSCLK
21	SA10	IRQ7
22	SA9	IRQ6
23	SA8	IRQ5
24	SA7	IRQ4
25	SA6	IRQ3
26	SA5	DACK2*
27	SA4	TC
28	SA3	BALE
29	SA2	+5V
30	SA1	OSC
31	SA0	0V
32	0V	0V

The following table lists signals of the AT portion of the PC/104 bus.

PC/104 AT Bus Connector, CN2

Pin	Row C	Row D
0	0V	0V
1	SBHE*	MEMCS16*
2	LA23	IOCS16*
3	LA22	IRQ10
4	LA21	IRQ11
5	LA20	IRQ12
6	LA19	IRQ15
7	LA18	IRQ14
8	LA17	DACK0*
9	MEMR*	DRQ0
10	MEMW*	DACK5*
11	SD8	DRQ5
12	SD9	DACK6*
13	SD10	DRQ6
14	SD11	DACK7*
15	SD12	DRQ7
16	SD13	+5V*
17	SD14	MASTER*
18	SD15	0V
19	(Keying pin)	0V

Notes:

- ISA bus refresh is not supported by this cpuModule.
- Keying pin positions have the pin cut on the bottom of the board and the hole plugged in the connector to prevent misalignment of stacked modules. This is a feature of the PC/104 specification and should be implemented on all mating PC/104 modules.
- Signals marked with (*) are active-low.
- All bus lines can drive a maximum current of 4 mA at TTL voltage levels.

PC/104 Bus Signals

The following table contains brief descriptions of the PC/104 bus signals.

PC/104 Bus Signals

Signal	I/O	Description
AEN	O	Address ENable: when this line is active (high), it means a DMA transfer is being performed, and therefore, the DMA controller has control over the data bus, the address bus, and the control lines.
BALE	O	Bus Address Latch Enable, active high. When active, it indicates that address lines SA0 to SA19 are valid.
DACKx*	O	DMA ACKnowledge x=0-7, active low, used to acknowledge DMA requests.
DRQx	I	DMA Request x=0-7: these are asynchronous lines used by peripheral devices to request DMA service. They have increasing priority from DRQ0 up to DRQ7. A DMA request is performed by setting the DRQ line high and keeping it high until the corresponding DACK line is activated.
ENDXFR*	I/O	This is the only synchronous signal of the PC/104 bus and it is active low. It indicates that the current bus cycle must be performed with 0 wait states. It is used only for 16-bit boards.
IOCHCHK*	I	I/O Channel Check, active low, indicates an error condition that cannot be corrected.
IOCHRDY	I	I/O Channel Ready: this line, usually high (ready) is pulled to a low level by devices which need longer bus cycles.
IOCS16*	I	I/O Chip Select 16-bit: this line, active low, is controlled by devices mapped in the I/O address space. It indicates they have a 16-bit bus width.
IOR*	O	I/O Read, active low, indicates when the devices present on the bus can send their information on the data bus.
IOW*	O	I/O Write, active low. When active, it allows the peripheral devices to read data present on the data bus.
IRQx	I	Interrupt Request: x = 2 to 15, active on rising edge. IRQ15 has top priority; the other lines have decreasing priority starting from IRQ14 down to IRQ2. An interrupt request is performed by changing the level of the corresponding line from low to high and keeping it high until the microprocessor has recognized it.
KEY	N/A	These locations contain mechanical keying pins to help prevent incorrect connector insertion.
LA23..LA17	O	These signals select a 128kbyte window in the 16Mbyte address space available on the bus.

PC/104 Bus Signals

MASTER*	I	During a DMA cycle, this active-low signal, indicates that a resource on the bus is about to drive the data and address lines.
MEMCS16*	I	Memory Chip Select 16-bit: this line, active low, is controlled by devices mapped in the memory address space and indicates they have a 16-bit bus width.
MEMR*	I/O	This active-low signal indicates a memory read operation. Devices using this signal must decode the address on lines LA23..LA17 and SA19..SA0.
MEMW*	I/O	This active-low signal indicates a memory write operation. Devices using this signal must decode the address on lines LA23..LA17 and SA19..SA0.
OSC	O	OSCillator: clock with a 70 ns period and a 50% duty cycle. It is a 14.31818 MHz always presents.
REFRESH*	I	This cpuModule does not support refresh on the ISA bus. This pin is pulled high with a 4.7 K ohm resistor and may be driven by another card in the PC/104 stack.
RESETDRV	O	This line, active high, is used to reset the devices on the bus, at power-on or after a reset command.
SA0..19	O	Address bits 0 to 19: these lines are used to address the memory space and the I/O space. SA0 is the least significant bit while SA19 is the most significant bit.
SBHE*	O	This active-low signal indicates a transfer of the most significant data byte (SD15..SD8).
SD8..15	I/O	Data bits: these are the high-byte data bus lines. SD8 is the least significant bit; SD15 the most significant bit.
SD0..7	I/O	Data bits: these are the low-byte data bus lines. SD0 is the least significant bit; SD7 the most significant bit.
SMEMR*	O	Memory Read command, active low.
SMEMW*	O	Memory Write command, active low.
SYSCLK	O	System Clock, 8.0MHz with a 50% duty cycle. Only driven during external bus cycles.
TC	O	Terminal Count: this line is active high and indicates the conclusion of a DMA transfer.

PC/104 Bus Termination

Termination of PC/104 bus signals is not recommended since this cpuModule incorporates source termination on bus signals and may cause malfunctions of the cpuModule.

PC/104-Plus PCI Bus, CN16

Connector CN16 carries the signals of the PC/104-Plus PCI bus. These signals match definitions of the PCI Local Bus specification Revision 2.1. The following tables list the pinouts of the PC/104-Plus bus connector.

PC/104-Plus Bus Signal Assignments

Pin	A	B	C	D
1	GND/5.0V KEY ¹	Reserved	+5V	AD00
2	VI/O	AD02	AD01	+5V
3	AD05	GND	AD04	AD03
4	C/BE0*	AD07	GND	AD06
5	GND	AD09	AD08	GND
6	AD11	VI/O	AD10	M66EN
7	AD14	AD13	GND	AD12
8	+3.3V	C/BE1*	AD15	+3.3V
9	SERR*	GND	SB0*	PAR
10	GND	PERR*	+3.3V	SDONE
11	STOP*	+3.3V	LOCK*	GND
12	+3.3V	TRDY*	GND	DEVSEL*
13	FRAME*	GND	IRDY*	+3.3V
14	GND	AD16	+3.3V	C/BE2*
15	AD18	+3.3V	AD17	GND
16	AD21	AD20	GND	AD19
17	+3.3V	AD23	AD22	+3.3V
18	IDSEL0	GND	IDSEL1	IDSEL2
19	AD24	C/BE3*	VI/O	IDSEL3
20	GND	AD26	AD25	GND
21	AD29	+5V	AD28	AD27
22	+5V	AD30	GND	AD31
23	REQ0*	GND	REQ1*	VI/O
24	GND	REQ2*	+5V	GNT0*
25	GNT1*	VI/O	GNT2*	GND
26	+5V	CLK0	GND	CLK1
27	CLK2	+5V	CLK3	GND
28	GND	INTD*	+5V	RST*
29	+12V	INTA*	INTB*	INTC*
30	-12V	Reserved	Reserved	GND/3.3V KEY ¹

Notes:

- The KEY pins are to guarantee proper module installation. Pin-A1 is removed and the female side plugged for 5.0V I/O signals and Pin-D30 is modified in the same manner for 3.3V I/O. It is recommended that both KEY pins (A1 and D30) be electrically connected to GND for shielding.

PC/104-Plus PCI Bus Signals

The following are brief descriptions of the PC/104-Plus PCI bus signals.

Address and Data

AD[31:00] -- Address and Data are multiplexed. A bus transaction consists of an address cycle followed by one or more data cycles.

C/BE[3:0]* -- Bus Command/Byte Enables are multiplexed. During the address cycle, the command is defined. During the Data cycle, they define the byte enables.

PAR -- Parity is even on AD[31:00] and C/BE[3:0]* and is required.

Interface Control Pins

FRAME* -- Frame is driven by the current master to indicate the start of a transaction and will remain active until the final data cycle.

TRDY* -- Target Ready indicates the selected device's ability to complete the current data cycle of the transaction. Both **IRDY*** and **TRDY*** must be asserted to terminate a data cycle.

IRDY* -- Initiator Ready indicates the master's ability to complete the current data cycle of the transaction.

STOP* -- Stop indicates the current selected device is requesting the master to stop the current transaction.

DEVSEL* -- Device Select is driven by the target device when its address is decoded.

IDSEL -- Initialization Device Select is used as a chip-select during configuration.

LOCK* -- Lock indicates an operation that may require multiple transactions to complete.

Error Reporting

PERR* -- Parity Error is for reporting data parity errors.

SERR* -- System Error is for reporting address parity errors.

Arbitration (Bus Masters Only)

REQ* -- Request indicates to the arbitrator that this device desires use of the bus.

GNT* -- Grant indicates to the requesting device that access has been granted.

System

CLK -- Clock provides timing for all transactions on the PCI bus.

RST* -- Reset is used to bring PCI-specific registers to a known state.

Interrupts

INTA* -- Interrupt A is used to request Interrupts.

INTB* -- Interrupt B is used to request Interrupts only for multi-function devices.

INTC* -- Interrupt C is used to request Interrupts only for multi-function devices.

INTD* -- Interrupt D is used to request Interrupts only for multi-function devices.

Power Supplies and VIO

+5V -- +5 volt supply connected to PC/104 bus and power connector +5V supplies.

+12V -- +12 volt supply connected to PC/104 bus and power connector +12V supplies.

-12V -- -12 volt supply connected to PC/104 bus and power connector -12V supplies.

+3.3V -- +3.3 volt supply is an on-board converter which can deliver up to 2 amps.

VIO -- This signal typically is the I/O power to the bus drivers on a PCI bus card. BL3 selects +3.3 or +5 volts to indicate +3.3 or +5 volt signaling. The default is +3.3 volts. No other device except this board should drive the VIO pin.

10/100 Base T and TX Connector CN18

The functionality of this port is based on the INTEL 82559ER Fast Ethernet PCI controller. The following table gives the pinout of CN18. The Ethernet controller can be disabled in the BIOS Set-up.

Table 2: 10/100 Base T and TX Connector CN18

RJ45 Pin	10 PIN DIL Pin	Signal	Function	in/out
1	1	TX+	Transmit +	Out
6	2	RX-	Receive -	In
2	3	TX-	Transmit -	Out
7	4	CT	Termination connected to pin 6	
3	5	RX+	Receive +	In
8	6	CT	Termination connected to pin 4	
4	7	CT	Termination connected to pin 9	
--	8	NC	Not Connected	
5	9	CT	Termination connected to pin 7	
--	10	NC	Not Connected	

Facing the connector the pinout is depicted below

9	7	5	3	1
NC	CT	RX+	TX-	TX+
NC	NC	CT	CT	RX-
10	8	6	4	2

CHAPTER 4: CONFIGURING THE CPU MODULE (BIOS SETUP)

This chapter contains information to configure the cpuModule.

Topics covered in this chapter include:

- Entering Setup
- Default Configuration
- Disabling Fail Safe Boot ROM
- Configuring Using the Setup Program
- Adding SSD Memory

Entering the BIOS Setup

- Apply power to the system
- Repeatedly press the DEL key to enter setup

Default Configuration

In addition to the Setup configuration stored on the board, the cpuModule has a permanent default configuration. The system will resort to using this default if an error occurs when accessing the EPROM which holds the Setup on the module.

The default configuration is listed below.

BIOS Default Configuration	
Function	Default selection
IDE Interface 0 Master	Auto detect
IDE Interface 0 Slave	Auto detect
IDE Interface 1 Master	Auto detect
IDE Interface 1 Slave	Auto detect
Boot device	Floppy then hard disk
BIOS Extension	Disabled
Floppy Drive 1	3.5" 1.44 Meg
Floppy Drive 2	not installed
Serial port 1	RS232 at 3F8H
Serial port 2	RS232 at 2F8H
Keyboard	Enabled if connected
USB	Enable if connected
Fail safe boot ROM	Enabled
Select Active Video	
Power Management	Disabled
PNP OS Installed	No
Resources Controlled By	Auto
PCI IRQ Activated By	Level
IDE HDD Block Mode	Enabled
KBC Input Clock	8 Mhz
SSD Window	D800:0000
Halt On	No Errors
Virus Warning	Disabled
CPU Internal Cache	Enabled
Cyrix 6X86/MII CPUID	Enabled
Swap Floppy Drive	Disabled
Boot Up Numlock Status	Off
Gate A20 Option	Fast
Security Option	Setup
Report No FDD for WIN95	Yes
Quick Boot	Disabled
Extended Memory Test	Disabled
ISA Plug-n-Play Support	Enabled
Video Bios Shadow	Enabled

C8000-DFFFF	Disabled
16-bit I/O Recovery (Clock)	5
8-bit I/O Recovery (Clock)	5
Ethernet	Enabled
a2DIO	Disabled
Digital I/O IRQ	IRQ5

NOTE!	<p>Boards are shipped with fail safe boot ROM enable. See the chapter on Configuring the cpuModule (BIOS setup) in Disabling Fail Safe Boot ROM for the method to disable it.</p> <p>When Fail Safe Boot ROM is enabled the system will boot to it exclusively.</p>
--------------	---

Disabling Fail Safe Boot ROM

- Reset the system by either shutting it off and turning it on or by using the reset button.
- while the system is booting repeatedly press the DEL key to enter the BIOS setup.
- Choose INTEGRATED PERIPHERALS using the arrow keys and enter.
- Once in INTEGRATED PERIPHERALS set Fail Safe Boot in SSD Win: Disabled

Installing SSD Memory

This section explains how to add SSD devices to the cpuModule. This procedure is only necessary when you wish to add or change Solid State Disk memory devices

You may wish to install SSD memory to use the cpuModule as a "diskless" stand-alone device.

Refer to *Storing Applications On-board* for more information on various SSD device types. Solid State Disk memories are placed in SSD socket U16

The following table lists possible configurations for the SSD socket:

SSD Support				
Type	Part	Operation	Capacity	Notes
Atmel 5V Flash	29C010A	read/write	128KB	
	29C040A	read/write	512KB	
BIOS Extension Devices	DiskOnChip and PromDisk Boot Block Flash	read/write	to 288 MB+	
NOVRAM	DS1645Y	read/write	128KB	
	DS1650Y	read/write	512KB	
SRAM	128KB	read/write	128KB	battery backup
	512KB	read/write	512KB	battery backup
12V Flash	28F010	read-only	128KB	read-only
	28F020	read-only	256KB	read-only
AMD 5V Flash	29F010	read-only	128KB	read-only
	29F040	read-only	512KB	read-only
EPROM	27C010	read-only	128KB	read-only
	27C020	read-only	256KB	read-only
	27C040	read-only	512KB	read-only
	27C080	read-only	1MB	read-only

Quick Boot Description

The BIOS contains a Quick Boot option which minimizes the boot time for standard time critical systems. Quick Boot eliminates the exhaustive tests that are performed during POST while maintaining the functionality of the board (see note #1). By enabling the Quick Boot feature, your system can achieve 5 second boot times as shown in the table below.

BIOS Settings and Boot Times

	Normal Boot	Quick Boot
Standard RTD Defaults	~ 16 seconds	< 10 seconds
Primary Master : None Primary Slave : None Secondary Master : None Secondary Slave : None Device in SSD Socket #1 : ATMEL-512k SSD Window : D800:0000 Drive A: : SSD	~ 20 seconds	< 6 seconds
Same configuration as above including ISA Plug-n-Play Support : Disabled	~ 18 seconds	< 5 seconds

To achieve boot times of 6 seconds or less, you will have to disable the HDD and possibly any other devices attached to the IDE controller. Booting to a SSD (see note #2) device is faster than a hard drive.

To achieve boot times of 5 seconds or less, ISA Plug-n-Play Support must be disabled. If there is not an ISA PnP card attached to your system then disabling this feature will save at least 1 second. Some modern operating systems (Windows) will automatically configure ISA PnP devices. If using one of these operating systems, ISA Plug-n-Play cards will still work even if it is disabled in the BIOS. Check with your OS vendor to see if ISA auto configuration is supported.

Quick Boot in conjunction with the watch dog timer allows frozen systems or systems with temporary power loss to become operable again within a few seconds. This can reduce the risk of complete system failure.

NOTE!

- 1) NumLock will always be off on boot up when Quick Boot is enabled
- 2) DiskOnChip devices contain their own embedded firmware. Boot times can vary because of its initialization process. Contact M-Systems for more information.

Configuring with the RTD Enhanced Award BIOS

The cpuModule Setup program allows you to customize the cpuModule's configuration. Selections made in Setup are stored on the board and are read by the BIOS at power-on.

Starting Setup

You can run Setup by:

- Re-boot the cpuModule, and press the {Del} key.

When you are finished with Setup, save your changes and exit. The system will automatically reboot.

Using the Setup Program

All displays in Setup consist of two areas. The left area lists the available selections. The right area displays help messages which you should always read.

Field Selection

You move between fields in Setup using the keys listed below.

Setup Keys

Key	Function
→,←, ↓,↑	move between fields
+, -, <PgUp>, <PgDn>	selects next/previous values in fields
<Enter>	Go to the submenu for the field.
<Esc>	to previous menu then to exit menu

Main Menu Setup Fields

The following is a list of Main menu Setup fields.

Main Menu Setup Fields

Field	Active keys	Selections
Standard CMOS Setup	Press <Enter> to select	Access commonly used settings for the floppy drives, hard disks, and video.
BIOS Features Setup	Press <Enter> to select	Access settings for BIOS features such as boot sequence, keyboard options and test options.
Chipset Features Setup	Press <Enter> to select	Set chipset specific options.
Power management Setup	Press <Enter> to select	Set power management options.
PNP/PCI Configuration Setup	Press <Enter> to select	Set PNP and PCI options.
Load RTD Defaults	Press <Enter> to select	Load setup defaults except Standard CMOS Setup
Integrated Peripherals	Press <Enter> to select	Set I/O device options
Supervisor Password	Press <Enter> to select	Set supervisor access password.
User Password	Press <Enter> to select	Set user access password.
IDE HDD Auto Detection	Press <Enter> to select	Have the BIOS detect the IDE hard disks connected to the system.
Save and Exit Setup	Press <Enter> to select	Save your changes and exit Setup.
Exit without Saving	Press <Enter> to select	Exit Setup without saving changes.

Standard CMOS Setup

The following is an alphabetical list of Standard CMOS Setup fields. BIOS Features Setup

Standard CMOS Setup Fields

Field	Active keys	Selections
Date	{0..9},{↵}	Sets the date with the format: <ul style="list-style-type: none"> • month / day / year • You must connect a backup battery, or this setting will be lost at power down.
Time	{0..9},{↵}	Sets the time with the format: <ul style="list-style-type: none"> • hour: minute: second • You must connect a backup battery, or this setting will be lost at power down.
Hard Disk Primary Master Primary Slave Secondary Master Secondary Slave	+, -, <PgUp>, <PgDn>	Selects the IDE hard disk type for each interface. An interface must have a master before a slave can be added. Make sure you configure the drive jumpers correctly. Selections are: <ul style="list-style-type: none"> • None • Auto (Auto detect drive parameters, not all drives can be auto detected) • 1 - 45 Standard drive types • USER (User enters drive parameters)
Drive A Drive B	+, -, <PgUp>, <PgDn>	Selects the format of each floppy disk: Selections are: <ul style="list-style-type: none"> • None • 360 KB, 5¼" Floppy • 1.2 MB, 5¼" Floppy • 720 KB, 3½" Floppy • 1.44/1.25 MB, 3½" Floppy • 2.88 MB, 3½" Floppy •

BIOS Features Setup

The following is a list of BIOS Features Setup fields.

BIOS Features Setup Fields

Field	Active keys	Selections
Virus warning	+, -, <PgUp>, <PgDn>	Enable or disable virus warning <ul style="list-style-type: none"> • Enable -- Warn if boot sector or partition table is being modified • Disable -- Allow boot sector or partition table modification
CPU Internal Cache	+, -, <PgUp>, <PgDn>	Enable or disable CPU internal cache <ul style="list-style-type: none"> • Enable -- Enable CPU internal 16 KB cache • Disable -- Disable CPU internal 16 KB cache
Boot Sequence	+, -, <PgUp>, <PgDn>	Select from the options the boot sequence for the CPU
Swap floppy drive	+, -, <PgUp>, <PgDn>	Swap floppy drive A: and B: <ul style="list-style-type: none"> • Enable -- Floppy connected after the twist in the floppy wire will be Drive B: and floppy connected before the twist in the floppy wire will be Drive A: • Disable (Normal) -- Floppy connected after the twist in the floppy wire will be Drive A: and floppy connected after the twist in the floppy wire will be Drive B: <p>Note: This only works with two floppies installed.</p>
Boot up numlock status	+, -, <PgUp>, <PgDn>	Set keypad numlock status after boot <ul style="list-style-type: none"> • On -- Keypad is number keys • Off -- Keypad is cursors keys
Gate A20 option	+, -, <PgUp>, <PgDn>	Select gate A20 options <ul style="list-style-type: none"> • Normal -- Use keyboard controller to control A20 gate • Fast -- Allow chipset to control A20 gate
Security option	+, -, <PgUp>, <PgDn>	Limit access with password to the system and setup or just setup <ul style="list-style-type: none"> • System -- The system will not boot and access to setup will be denied if the correct password is not entered at the prompt • Setup -- The system will boot but, access to setup will be denied if the correct password is not entered at the prompt <p>Note: To disable security, select Password setting at the main menu and then you will be asked to enter a password. Do not type anything, just press <Enter> and it will disable security. Once security is disabled, you can boot and enter setup freely.</p>
Report No FDD for Win95	+, -, <PgUp>, <PgDn>	Enable reporting that there is no floppy disk drives to Win 95 <ul style="list-style-type: none"> • Yes -- Report to Win 95 if there are no floppies • No -- Do not report to Win 95 if there are no floppies

BIOS Features Setup Fields

Quick Boot	+, -, <PgUp>, <PgDn>	Enables or Disables Quick Boot <ul style="list-style-type: none"> • Disable • Enable Overrides Extended Memory Test Selection and disables Boot Up Numlock Status
Extended Memory Test	+, -, <PgUp>, <PgDn>	Enable or Disable Extended Memory Test <ul style="list-style-type: none"> • Disable • Enable
ISA Plug-n-Play Support	+, -, <PgUp>, <PgDn>	Enable or Disable ISA Plug-n-Play Support <ul style="list-style-type: none"> • Disable • Enable
BIOS shadowing	+, -, <PgUp>, <PgDn>	Enable or disable copying slow ROMs to fast DRAM for the following memory areas: <ul style="list-style-type: none"> • Video BIOS -- C0000 - C7FFFF • C8000 - CBFFF • CC000 - CFFFF • D0000 - D3FFF • D4000 - D7FFF • D8000 - DBFFF • DC000 - DFFFF
Cyrix 6x86/MII CPUID	+, -, <PgUp>, <PgDn>	Enable or disable the CPUID instruction <ul style="list-style-type: none"> • Enable -- Allow the CPUID instruction • Disable -- Don't allow the CPUID instruction

Chipset Features Setup

The following is a list of Chipset Features Setup fields.

Chipset Features Setup Fields

Recovery time is the length of time, measured in CPU clocks, which the system will delay after the completion of an input/output request. This delay takes place because the CPU is operating so much faster than the I/O bus that the CPU must be delayed to allow for the completion of the I/O.		
Field	Active keys	Selections
16-bit I/O recovery (Clocks)	+, -, <PgUp>, <PgDn>	Set the recovery time for 16-bit I/O cycles. Selection is from 1 to 16 clocks. Default is 5.
8-bit I/O recovery (Clocks)	+, -, <PgUp>, <PgDn>	Set the recovery time for 8-bit I/O cycles. Selection is from 1 to 16 clocks. Default is 5.
USB Controller	+, -, <PgUp>, <PgDn>	<ul style="list-style-type: none">• Enable• Disable
USB Legacy Support	+, -, <PgUp>, <PgDn>	<ul style="list-style-type: none">• Enable• Disable

Power Management Setup Fields

The following is a list of Power Management Setup fields.

Power Management Setup Fields

Field	Active keys	Selections
Power management	+, -, <PgUp>, <PgDn>	Select power management mode <ul style="list-style-type: none">• Disable -- Power management off• Min Saving -- Minimum power savings, maximum performance• Max Saving -- Maximum power savings, minimum performance• User Defined -- User selects the power management functions to suit the application
Doze Mode	+, -, <PgUp>, <PgDn>	Select inactivity time delay before entering doze mode <ul style="list-style-type: none">• Disable -- Doze mode off• 1 -- 1 Second• 2 -- 2 Seconds• 4 -- 4 Seconds• 8 -- 8 Seconds• 10 -- 10 Seconds• 12 -- 12 Seconds• 15 -- 15 Seconds• 16 -- 16 Seconds
Standby Mode	+, -, <PgUp>, <PgDn>	Select inactivity time delay before entering standby mode <ul style="list-style-type: none">• Disable -- Standby mode off• 1 -- 1 Minute• 2 -- 2 Minutes• 4 -- 4 Minutes• 8 -- 8 Minutes• 10 -- 10 Minutes• 12 -- 12 Minutes• 15 -- 15 Minutes• 16 -- 16 Minutes• 20 -- 20 Minutes• 30 -- 30 Minutes• 40 -- 40 Minutes• 60 -- 60 Minutes

Power Management Setup Fields

HDD Power Down	+, -, <PgUp>, <PgDn>	<p>Select inactivity time delay before hard disk power down</p> <ul style="list-style-type: none"> • Disable -- HDD power down off • 1 -- 1 Minute • 2 -- 2 Minutes • 4 -- 4 Minutes • 8 -- 8 Minutes • 10 -- 10 Minutes • 12 -- 12 Minutes • 15 -- 15 Minutes • 16 -- 16 Minutes • 20 -- 20 Minutes • 30 -- 30 Minutes • 40 -- 40 Minutes • 60 -- 60 Minutes
Modem use IRQ	+, -, <PgUp>, <PgDn>	<p>Select IRQ for modem wakeup</p> <ul style="list-style-type: none"> • NA -- Not Available • 3 -- IRQ 3 • 4 -- IRQ 4 • 5 -- IRQ 5 • 7 -- IRQ 7 • 9 -- IRQ 9 • 10 -- IRQ 10 • 11 -- IRQ 11
Throttle Duty Cycle	+, -, <PgUp>, <PgDn>	<p>Select throttle duty cycle.</p> <ul style="list-style-type: none"> • 12.5 -- 12.5% Minimum savings • 33.3 -- 33.3% • 50.0 -- 50.0% • 75.0 -- 75.0% Maximum savings
RINGPOWER ON Controller	+, -, <PgUp>, <PgDn>	<ul style="list-style-type: none"> • Enable • Disable
NET POWER ON Controller	+, -, <PgUp>, <PgDn>	<ul style="list-style-type: none"> • Enable • Disable
RTC Alarm Function	+, -, <PgUp>, <PgDn>	<ul style="list-style-type: none"> • Enable • Disable
RTC On by Time (hh:mm)	hh:mm	<ul style="list-style-type: none"> • hh:mm

Power Management Setup Fields

IRQ that will bring the CPU out of power management	+, -, <PgUp>, <PgDn>	Select IRQs that will wake the CPU out of suspend mode <ul style="list-style-type: none">• IRQ 1• IRQ 3• IRQ 4• IRQ 5• IRQ 6• IRQ 7• IRQ 9• IRQ 10• IRQ 11• IRQ 12• IRQ 13• IRQ 14• IRQ 15
---	----------------------	--

PNP/PCI Configuration Setup Fields

The following is a list of PNP/PCI Configuration Setup fields.

PNP/PCI Configuration Setup Fields

Field	Active keys	Selections
PNP OS installed	+, -, <PgUp>, <PgDn>	Select if you are using a PNP aware operating system. If you select Yes the Operating System will change the I/O assignments made in the BIOS. <ul style="list-style-type: none"> • Yes -- Using a PNP operating system such as Microsoft Windows 95/98/NT • No -- Not using a PNP operating system
Resources controlled by	+, -, <PgUp>, <PgDn>	How PNP resources are controlled <ul style="list-style-type: none"> • Auto -- BIOS configures the PNP devices • Manual -- User configures PNP devices
Reset Configuration Data	+, -, <PgUp>, <PgDn>	Select Enable to clear the Extended System Configuration Data (ESCD) area. This will make the CPU search for legacy devices and store the updated info. This field will automatically return to disable after the next boot.
IRQ assigned to	+, -, <PgUp>, <PgDn>	Select whether interrupts are to be used by legacy ISA devices or PCI/PNP ISA devices. <ul style="list-style-type: none"> • IRQ 3 -- PCI/ISA PNP or Legacy ISA • IRQ 4 -- PCI/ISA PNP or Legacy ISA • IRQ 5 -- PCI/ISA PNP or Legacy ISA • IRQ 6 -- PCI/ISA PNP or Legacy ISA • IRQ 7 -- PCI/ISA PNP or Legacy ISA • IRQ 9 -- PCI/ISA PNP or Legacy ISA • IRQ 10 -- PCI/ISA PNP or Legacy ISA • IRQ 11 -- PCI/ISA PNP or Legacy ISA • IRQ 12 -- PCI/ISA PNP or Legacy ISA • IRQ 13 -- PCI/ISA PNP or Legacy ISA • IRQ 14 -- PCI/ISA PNP or Legacy ISA • IRQ 15 -- PCI/ISA PNP or Legacy ISA
PCI IRQ activated by	+, -, <PgUp>, <PgDn>	Select if PCI interrupts are level or edge sensitive.
Used memory base address	+, -, <PgUp>, <PgDn>	Select the starting address of an upper memory region to exclude from PCI/PNP usage: <ul style="list-style-type: none"> • NA -- Upper memory not used by legacy ISA devices • C800h • CC00h • D000h • D400h • D800h • DC00h

PNP/PCI Configuration Setup Fields

Used memory length	+, -, <PgUp>, <PgDn>	Select the length of an upper memory region to exclude from PCI/PNP usage: <ul style="list-style-type: none">• 8 KB• 16 KB• 32 KB• 64 KB
--------------------	----------------------------	---

Integrated Peripherals Setup Fields

The following is a list of Integrated Peripherals Setup fields.

Integrated Peripherals Setup Fields

Field	Active keys	Selections
IDE block mode	+, -, <PgUp>, <PgDn>	Allows the IDE controller to use fast block mode to transfer data to and from the hard disk. <ul style="list-style-type: none"> • Enable -- IDE controller uses block mode • Disable -- IDE controller does not uses block mode
Keyboard input clock	+, -, <PgUp>, <PgDn>	Select the clock to be used for the keyboard controller <ul style="list-style-type: none"> • 8 -- 8 MHz - Default • 12 -- 12 MHz • 16 -- 16 MHz
Onboard Serial Port 1:	+, -, <PgUp>, <PgDn>	Serial port 1, connector CN7 settings: <ul style="list-style-type: none"> • Disable -- Serial port not used • Auto -- BIOS/OS controls operation • 3F8h/IRQ 4 -- Address 3F8h and interrupt 4 • 2F8h/IRQ 3 -- Address 2F8h and interrupt 3 • 3E8h/IRQ 4 -- Address 3E8h and interrupt 4 • 2E8h/IRQ 3 -- Address 2E8h and interrupt 3
Mode	+, -, <PgUp>, <PgDn>	Select mode for onboard serial port 1 <ul style="list-style-type: none"> • RS-232 -- RS-232 driver/receiver enabled • RS-422/485 -- RS-422/485 driver/receiver enabled
Onboard Serial Port 2:	+, -, <PgUp>, <PgDn>	Serial port 2, connector CN8 settings: <ul style="list-style-type: none"> • Disable -- Serial port not used • Auto -- BIOS/OS controls operation • 3F8h/IRQ 4 -- Address 3F8h and interrupt 4 • 2F8h/IRQ 3 -- Address 2F8h and interrupt 3 • 3E8h/IRQ 4 -- Address 3E8h and interrupt 4 • 2E8h/IRQ 3 -- Address 2E8h and interrupt 3
Mode	+, -, <PgUp>, <PgDn>	Select mode for onboard serial port 2 <ul style="list-style-type: none"> • RS-232 -- RS-232 driver/receiver enabled • RS-422/485 -- RS-422/485 driver/receiver enabled
BIOS extension window	+, -, <PgUp>, <PgDn>	Select a 32 KB memory window for BIOS extension devices in the 32-pin SSD socket such as DiskOnChip® <ul style="list-style-type: none"> • Disable -- Do not use BIOS extension device • C800 -- Window at C8000h - CFFFFh (if USB is enabled these addresses are used) • D000 -- Window at D0000h - D7FFFh • D800 -- Window at D8000h - DFFFFh

Integrated Peripherals Setup Fields

device in SSD Socket	+, -, <PgUp>, <PgDn>	<p>Select a SSD device to fill the SSD socket</p> <ul style="list-style-type: none"> • None • RAM-128k • RAM-512k • NOVRAM-128k • NOVRAM-512k • ATMEL-128k • ATMEL-512k • FLASH-128k • FLASH-256k • FLASH-512k • EPROM-128k • EPROM-256k • EPROM-512k • EPROM-1M • BiosExt
SSD Window	+, -, <PgUp>, <PgDn>	<p>Sets the memory window to be used for the SSD device</p> <ul style="list-style-type: none"> • D000:0000 • D800:0000 • C800:0000
Drive A: (except BiosExt)	+, -, <PgUp>, <PgDn>	<p>Selects the device the CPU will consider to be A:</p> <ul style="list-style-type: none"> • Floppy • SSD
Fail Safe Boot in SSD Win	+, -, <PgUp>, <PgDn>	<p>Enables the non-volatile, onboard backup BIOS</p> <ul style="list-style-type: none"> • Enable • Disable
Ethernet	+, -, <PgUp>, <PgDn>	<ul style="list-style-type: none"> • Enable • Disable
a2DIO Base Address (CN19)	+, -, <PgUp>, <PgDn>	<ul style="list-style-type: none"> • Disable • 0x040 to 0x7C0 (31 Base Address Options)
a2DIO IRQ	+, -, <PgUp>, <PgDn>	<ul style="list-style-type: none"> • Disable • IRQ5 • IRQ7 • IRQ10 • IRQ11 • IRQ12 (MAKE SURE PS/2 IS NOT CONNECTED)

Integrated Peripherals Setup Fields

Digital I/O IRQ	+, -, <PgUp>, <PgDn>	<ul style="list-style-type: none">• Disable• IRQ5• IRQ7• IRQ10• IRQ11• IRQ12 (MAKE SURE PS/2 IS NOT CON- NECTED)
--------------------	----------------------------	---

CHAPTER 5: USING THE CPU MODULE

This chapter provides information for users who wish to develop their own applications programs for the cpuModule.

This chapter includes information on the following topics:

- Memory map
- I/O Address map
- Interrupts
- Power On Self Tests (POSTs)
- System Functions (Watchdog Timer, Real Time Clock)
- Storing Applications in Solid State Disk
- Utility Programs

Memory Map

The ISA portion of the cpuModule addresses memory using 24 address lines. This allows a maximum of 2^{24} locations, or 16 Megabytes of memory.

The table below shows how memory in the first megabyte is allocated in the system.

First Megabyte Memory Map		
FFFFFH-C0000H ROM	256 KB BIOS in Flash EPROM, shadowed into DRAM during runtime.	
EFFFFH-C0000H	Run time user memory space. Usually, memory between C0000H and C7FFFH is used for the BIOS of add-on VGA video cards.	
BFFFFH-A0000H	Normally used for video RAM as follows:	
	EGA/VGA Monochrome CGA	0A0000H to 0AFFFFH 0B0000H to 0B7FFFH 0B8000H to 0BFFFFH
9FFFFH-00502H	DOS reserved memory area	
00501H-00400H	BIOS data area	
003FFH-00000H	Interrupt vector area	

Memory beyond the first megabyte can be accessed in real mode, by using EMS or a similar memory manager. See your OS or programming language references for information on memory managers.

Input/Output Address Map

As with all standard PC/104 boards, the Input/Output (I/O) space is addressed by 10 address lines (SA0-SA9). This allows 2^{10} or 1024 distinct I/O addresses. Any add-on modules you install must therefore use I/O addresses in the range 0-1023 (decimal) or 000-3FF (hex).

	<p>If you add any PC/104 modules or other peripherals to the system you must ensure they <i>do not</i> use reserved addresses listed below, or mal-functions will occur. The exception to this is if the resource has been released by the user.</p>
---	--

The table below lists I/O addresses reserved for the cpuModule.

I/O Addresses Reserved for the cpuModule		
Address Range	Bytes	Device
000H-00FH	16	DMA Controller
010H-01FH	16	Reserved for CPU
020H-021H	2	Interrupt Controller #1
022H-02FH	13	Reserved
040H-043H	4	Timer
060H-064H	5	Keyboard Interface
070H-071H	2	Real Time Clock port
080H-08FH	16	DMA page register
0A0H-0A1H	2	Interrupt controller #2
0C0H-0DFH	32	DMA controller #2
0F0H-0FFH	16	Math co-processor
100H-101H	2	Video Initialization
1F0H-1FFH	16	Hard disk ¹
200H-201H	2	Reserved
238H-23BH	4	Bus Mouse ⁴
2E8H-2EFH	8	Serial Port ²
2F8H-2FFH	8	Serial port ²
3E8H-3EFH	8	Serial port ²
3F0H-3F7H	8	Floppy disk ¹

3F8H-3FFH	8	Serial port ²
450H-453H	4	aDIO (Advanced Digital I/O)
(Select in BIOS)	32	a2DIO

¹ If a floppy or IDE controller is not connected to the system, the I/O addresses listed will not be occupied.

² Only one of the I/O addresses shown for a Serial port is active at any time. You can use Setup to select which one is active or to disable it entirely.

⁴ If a PS2 mouse is not connected to the system, the I/O addresses listed will not be occupied.

Hardware Interrupts

	<p>If you add any PC/104 modules or other peripherals to the system you must ensure they <i>do not</i> use interrupts needed by the cpuModule, or malfunctions will occur</p>
---	---

The cpuModule supports the standard PC interrupts listed below. Interrupts not in use by hardware on the cpuModule itself are listed as 'available'.

Hardware Interrupts Used on the cpuModule		
Interrupt	Normal Use	Source
0	Timer 0	On-board ISA device
1	Keyboard	On-board ISA device
2	Cascade of IRQ 8-15	On-board ISA device
3	COM2	On-board ISA device
4	COM1	On-board ISA device
5	available	XT bus
6	Floppy ¹	XT bus
7	Printer	On-board ISA device
8	Real Time Clock	On-board ISA device
9	available, routed to IRQ 2	XT bus
10	available	AT bus
11	available	AT bus
12	Bus mouse	On-board ISA device
14	primary IDE hard disk ²	AT bus
15	available sometimes used as secondary IDE hard disk	AT bus

¹ Floppy disk interrupt, INT6, is available for use if no floppy disk is present in the system and floppy disk is disabled in Setup.

² Hard disk interrupt, INT14, is available for use if no hard disk drive is present in the system and hard disk is disabled in Setup.

The RTD Enhanced Award BIOS

The RTD Enhanced Award BIOS (Basic Input/Output System) is software that interfaces hardware-specific features of the cpuModule to an operating system (OS). Physically, the BIOS software is stored in a Flash EPROM on the cpuModule. Functions of the BIOS are divided into two parts:

The first part of the BIOS is known as POST (Power-On Self-Test) software, and it is active from the time power is applied until an OS boots (begins execution). POST software performs a series of hardware tests, sets up the machine as defined in Setup, and begins the boot of the OS;

The second part of the BIOS is known as the CORE BIOS. It is the normal interface between cpuModule hardware and the operating system which is in control. It is active from the time the OS boots until the cpuModule is turned off. The CORE BIOS provides the system with a series of software interrupts to control various hardware devices.

The following sections discuss the sections of the BIOS in more detail and describe features of the BIOS which may be useful to you in developing applications.

Power On Self Tests (POSTs)

POST Messages

During the Power On Self Test (POST), if the BIOS detects an error requiring you to do something to fix, it will either sound a beep code or display a message.

If a message is displayed, it will be accompanied by:

PRESS F1 TO CONTINUE, CTRL-ALT-ESC OR DEL TO ENTER SETUP

POST Beep

Currently there are two kinds of beep codes in BIOS. This code indicates that a video error has occurred and the BIOS cannot initialize the video screen to display any additional information. This beep code consists of a single long beep followed by three short beeps. The other code indicates that your DRAM error has occurred. This beep code consists of a single long beep repeatedly.

Error Messages

One or more of the following messages may be displayed if the BIOS detects an error during the POST. This list includes messages for both the ISA and the EISA BIOS.

CMOS BATTERY HAS FAILED

CMOS battery is no longer functional. It should be replaced.

CMOS CHECKSUM ERROR

Checksum of CMOS is incorrect. This can indicate that CMOS has become corrupt. This error may have been caused by a weak battery. Check the battery and replace if necessary.

DISK BOOT FAILURE, INSERT SYSTEM DISK AND PRESS ENTER

No boot device was found. This could mean that either a boot drive was not detected or the drive does not contain proper system boot files. Insert a system disk into Drive A: and press <Enter>. If you assumed the system would boot from the hard drive, make sure the controller is inserted correctly and all cables are properly attached. Also be sure the disk is formatted as a boot device. Then re-boot the system.

DISKETTE DRIVES OR TYPES MISMATCH ERROR - RUN SETUP

Type of diskette drive installed in the system is different from the CMOS definition. Run Setup to reconfigure the drive type correctly.

DISPLAY TYPE HAS CHANGED SINCE LAST BOOT

Since last powering off the system, the display adapter has been changed. You must configure the system for the new display type.

ERROR ENCOUNTERED INITIALIZING HARD DRIVE

Hard drive cannot be initialized. Be sure the adapter is installed correctly and all cables are correctly and firmly attached. Also be sure the correct hard drive type is selected in Setup.

ERROR INITIALIZING HARD DISK CONTROLLER

Cannot initialize controller. Make sure the cord is correctly and firmly installed in the bus. Be sure the correct hard drive type is selected in Setup. Also check to see if any jumper needs to be set correctly on the hard drive.

FLOPPY DISK CNTRLR ERROR OR NO CNTRLR PRESENT

Cannot find or initialize the floppy drive controller. Make sure the controller is installed correctly and firmly. If there are no floppy drives installed, be sure the Diskette Drive selection in Setup is set to NONE.

KEYBOARD ERROR OR NO KEYBOARD PRESENT

Cannot initialize the keyboard. Make sure the keyboard is attached correctly and no keys are being pressed during the boot.

If you are purposely configuring the system without a keyboard, set the error halt condition in Setup to HALT ON ALL, BUT KEYBOARD. This will cause the BIOS to ignore the missing keyboard and continue the boot.

MEMORY ADDRESS ERROR AT...

Indicates a memory address error at a specific location. You can use this location along with the memory map for your system to find and replace the bad memory chips.

MEMORY PARITY ERROR AT...

Indicates a memory parity error at a specific location. You can use this location along with the memory map for your system to find and replace the bad memory chips.

MEMORY SIZE HAS CHANGED SINCE LAST BOOT

Memory has been added or removed since the last boot. In EISA mode use Configuration Utility to reconfigure the memory configuration. In ISA mode enter Setup and enter the new memory size in the memory fields.

MEMORY VERIFY ERROR AT...

Indicates an error verifying a value already written to memory. Use the location along with your system's memory map to locate the bad chip.

OFFENDING ADDRESS NOT FOUND

This message is used in conjunction with the I/O CHANNEL CHECK and RAM PARITY ERROR messages when the segment that has caused the problem cannot be isolated.

OFFENDING SEGMENT:

This message is used in conjunction with the I/O CHANNEL CHECK and RAM PARITY ERROR messages when the segment that has caused the problem has been isolated.

PRESS A KEY TO REBOOT

This will be displayed at the bottom screen when an error occurs that requires you to reboot. Press any key and the system will reboot.

PRESS F1 TO DISABLE NMI, F2 TO REBOOT

When BIOS detects a Non-maskable Interrupt condition during boot, this will allow you to disable the NMI and continue to boot, or you can reboot the system with the NMI enabled.

RAM PARITY ERROR - CHECKING FOR SEGMENT...

Indicates a parity error in Random Access Memory.

SYSTEM HALTED, (CTRL-ALT-DEL) TO REBOOT...

Indicates the present boot attempt has been aborted and the system must be rebooted. Press and hold down the CTRL and ALT keys and press DEL.

FLOPPY DISK(S) fail (80) - Unable to reset floppy subsystem.

FLOPPY DISK(S) fail (40) - Floppy Type mismatch.

Hard Disk(s) fail (80) - HDD reset failed

Hard Disk(s) fail (40) - HDD controller diagnostics failed.

Hard Disk(s) fail (20) - HDD initialization error.

Hard Disk(s) fail (10) - Unable to calibrate fixed disk.

Hard Disk(s) fail (08) - Sector Verify failed.

KEYBOARD ERROR OR NO KEYBOARD PRESENT

Cannot initialize the keyboard. Make sure the keyboard is attached correctly and no keys are being pressed during the boot.

BIOS ROM CHECKSUM ERROR - SYSTEM HALTED

The checksum of ROM address F0000H-FFFFFFH is bad.

MEMORY TEST FAIL

BIOS reports the memory test fail if the onboard memory is tested error.

RTD Enhanced Award BIOS POST Codes

POST (hex)	Description
01	Clear base memory 0~640K
02	Reserved
03	Initialize EISA registers (EISA BIOS only)
04	Reserved
05	1. Keyboard Controller Self-Test 2. Enable Keyboard Interface
06	Reserved
07	Verifies CMOS's basic R/W functionality
09	1. Program the configuration register of Cyrix CPU according to the MODBINable Cyrix Register Table 2. OEM specific cache initialization (if needed)
0A	1. Initialize the first 32 interrupt vectors with corresponding Interrupt handlers Initialize INT no from 33-120 with Dummy(Spurious) Interrupt Handler 2. Issue CPUID instruction to identify CPU type 3. Early Power Management initialization (OEM specific)
0B	1. Verify the RTC time is valid or not 2. Detect bad battery 3. Read CMOS data into BIOS stack area 4. PnP initialization including (PnP BIOS only) -Assign CSN to PnP ISA card -Create resource map from ESCD 5. Assign IO & Memory for PCI devices (PCI BIOS only)
0C	Initialization of the BIOS Data Area (40: 00 - 40:FF)
0D	1. Program some of the Chipset's value according to Setup. (Early Setup Value Program) 2. Measure CPU speed for display & decide the system clock speed 3. Video initialization including Monochrome, CGA, EGA/VGA. If no display device found, the speaker will beep which consists of one single long beep followed by two short beeps.
0E	1. Initialize the APIC (Multi-Processor BIOS only) 2. Test video RAM (If Monochrome display device found) 3. Show messages including:-Award Logo, Copyright string, BIOS Date code & Part No. -OEM specific sign on messages -Energy Star Logo (Green BIOS ONLY)-CPU brand, type & speed -Test system BIOS checksum (Non-Compress Version only)
0F	DMA channel 0 test
10	DMA channel 1 test
11	DMA page registers test
12-13	Reserved

RTD Enhanced Award BIOS POST Codes

14	Test 8254 Timer 0 Counter 2.
15	Test 8259 interrupt mask bits for channel 1
16	Test 8259 interrupt mask bits for channel 2
17	Reserved
19	Test 8259 functionality
30	Detect Base Memory & Extended Memory Size
31	1. Test Base Memory from 256K to 640K 2. Test Extended Memory from 1M to the top of memory
32	1. Display the Award Plug & Play BIOS Extension message (PnP BIOS only) 2. Program all onboard super I/O chips (if any) including COM ports, LPT ports, FDD port according to setup value
41	Initialize floppy disk drive controller
42	Initialize Hard drive controller
43	If it is a PnP BIOS, initialize serial & parallel ports
44	Reserved
45	Initialize math coprocessor.
50	Write all CMOS values currently in the BIOS stack area back into the CMOS
51	Reserved
52	1. Initialize all ISA ROMs 2. Later PCI initialization (PCI BIOS only)-assign IRQ to PCI devices-initialize all PCI ROMs 3. PnP Initialization (PnP BIOS only) -assign IO, Memory, IRQ & DMA to PnP ISA devices -initialize all PnP ISA ROMs 4. Program shadows RAM according to Setup settings 5. Program parity according to Setup setting 6. Power Management Initialization-Enable/Disable global PM-APM interface initialization
53	1. If it is NOT a PnP BIOS, initialize serial & parallel ports 2. Initialize time value in BIOS data area by translate the RTC time value into a timer tick value
60	Setup Virus Protection (Boot Sector Protection) functionality according to Setup setting
1A-1D	Reserved
1E	If EISA NVM checksum is good, execute EISA initialization (EISA BIOS only)
1F-29	Reserved
33-3B	Reserved
3C	Set flag to allow users to enter CMOS Setup Utility

RTD Enhanced Award BIOS POST Codes

3D	<ol style="list-style-type: none"> 1. Initialize Keyboard 2. Install PS2 mouse
3E	<p>Try to turn on Level 2 cache</p> <p>Note: Some chipset may need to turn on the L2 cache in this stage. But usually, the cache is turn on later in POST 61h</p>
41H	Enable FDD and detect media type
46-4D	Reserved
4E	If there is any error detected (such as video, kb...), show all the error messages on the screen & wait for user to press <F1> key
4F	<ol style="list-style-type: none"> 1. If password is needed, ask for password 2. Clear the Energy Star Logo (Green BIOS only)
BE	Program defaults values into chipset according to the MODBINable Chipset Default Table
BF	<ol style="list-style-type: none"> 1. Program the rest of the Chipset's value according to Setup. (Later Setup Value Program) 2. If auto-configuration is enabled, programmed the chipset with pre-defined values in the MODBINable Auto-Table
C0	<ol style="list-style-type: none"> 1. Turn off OEM specific cache, shadow... 2. Initialize all the standard devices with default values standard devices includes: <ul style="list-style-type: none"> -DMA controller (8237) -Programmable Interrupt Controller (8259) -Programmable Interval Timer (8254) -RTC chip
C1	Auto-detection of onboard DRAM & Cache
C3	<ol style="list-style-type: none"> 1. Test system BIOS checksum 2. Test the first 256K DRAM 3. Expand the compressed codes into temporary DRAM area including the compressed System BIOS & Option ROMs
C5	Copy the BIOS from ROM into E0000-FFFFFF shadow RAM so that POST will go faster
FFH	System Booting INT 19

Default Configuration

In addition to the Setup configuration stored on the board, the cpuModule has a permanent default configuration. The system will resort to using this default if an error occurs when accessing the EPROM which holds the Setup on the module.

The default configuration is listed below.

BIOS Default Configuration	
Function	Default selection
IDE Interface 0 Master	Auto detect
IDE Interface 0 Slave	Auto detect
IDE Interface 1 Master	Auto detect
IDE Interface 1 Slave	Auto detect
Boot device	Floppy then hard disk
BIOS Extension	Disabled
Floppy Drive 1	3.5" 1.44 Meg
Floppy Drive 2	not installed
Serial port 1	RS232 at 3F8H
Serial port 2	RS232 at 2F8H
Keyboard	Enabled if connected
USB	Enable if connected
Fail safe boot ROM	Enabled
Select Active Video	
Power Management	Disabled
PNP OS Installed	No
Resources Controlled By	Auto
PCI IRQ Activated By	Level
IDE HDD Block Mode	Enabled
KBC Input Clock	8 Mhz
SSD Window	D800:0000
Halt On	No Errors
Virus Warning	Disabled
CPU Internal Cache	Enabled
Cyrix 6X86/MII CUID	Enabled
Swap Floppy Drive	Disabled
Boot Up Numlock Status	Off
Gate A20 Option	Fast
Security Option	Setup
Report No FDD for WIN95	Yes
Quick Boot	Disabled
Extended Memory Test	Disabled
ISA Plug-n-Play Support	Enabled

Video Bios Shadow	Enabled
C8000-DFFFF	Disabled
16-bit I/O Recovery (Clock)	5
8-bit I/O Recovery (Clock)	5
Ethernet	Enabled
a2DIO	Disabled
Digital I/O IRQ	IRQ5

Bypassing the Stored Configuration

Under certain circumstances, you may want to bypass the configuration stored on the board. To do this press the {Del} key to enter Setup and then you can then reconfigure the cpuModule correctly.

Direct Hardware Control

Some of the cpuModule hardware is controlled directly without using BIOS routines. These include:

- Advanced Digital I/O (aDIO)
- Advanced Level 2 Digital I/O (a2DIO)
- Watchdog Timer
- Real Time Clock Control

The following sections describe use of these features.

Advanced Digital I/O Ports (aDIO)

This board supports 16 bits of TTL/CMOS compatible digital I/O (TTL signalling). These I/O lines are grouped into two ports, port 0 and port 1. Port 0 is bit programmable and Port 1 is byte programmable. Port 0 supports RTD's two Advanced Digital Interrupt modes, ADI. The two modes are match and event. Match mode generates an interrupt when an eight bit pattern is received in parallel that matches the match mask register. The second ADI mode generates an interrupt when a change occurs on any bit. In either mode masking can be used to monitor selected lines.

When the CPU boots all digital I/O line are programmed as inputs. What this condition means is the digital I/O line's initial state is undetermined. If the digital I/O lines must power up to a known state an external 10 K Ohm resistor must be added to pull the line high or low. Additionally, when the CPU boots up interrupts 5, 7, 10, 11, and 12 are masked off.

The 8 bit control R/W registers for the digital I/O lines are located from I/O address 450H to 453H. These registers are written to zero upon power up. From 450H to 453H the name of these registers are **Port 0 data**, **Port 1 data**, **Multi-Function**, and **DIO-Control** register.

Digital I/O Register Set

Port 0 data I/O address 450 HEX

D7	D6	D5	D4	D3	D2	D1	D0
P0.7	P0.6	P0.5	P0.4	P0.3	P0.2	P0.1	P0.0

Port 0 Data register is a read/write bit direction programmable register. A particular bit can be set to input or output. A read of an input bit returns the value of port 0. A read of an output bit returns the last value written to Port 0. A write to an output bit sends that value to port zero.

Port 1 data I/O address 451 HEX

D7	D6	D5	D4	D3	D2	D1	D0
P1.7	P1.6	P1.5	P1.4	P1.3	P1.2	P1.1	P1.0

Port 1 Data register is a read/write byte direction programmable register. A read on this register when it is programmed to input will read the value at the DIO connector. A write on this register when it is programmed as output will write the value to the DIO connector. A read on this register when it is set to output will read the last value sent to the DIO connector.

Multi-Function I/O address 452 HEX

D7	D6	D5	D4	D3	D2	D1	D0
----	----	----	----	----	----	----	----

Multi-Function register is a read/write register whose contents are set by the DIO-Control register. See the DIO-Control register description for a description of this register.

DIO-Control I/O address 453 HEX Read Access

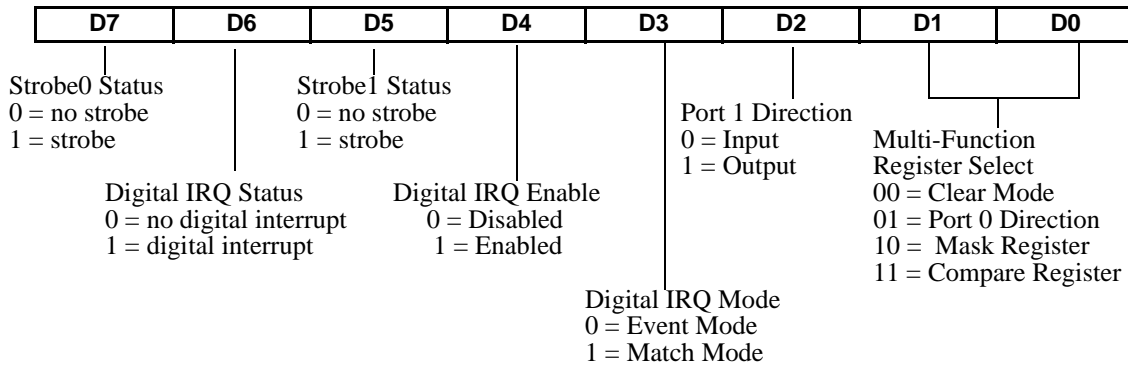

DIO-Control I/O address 453 HEX Write Access

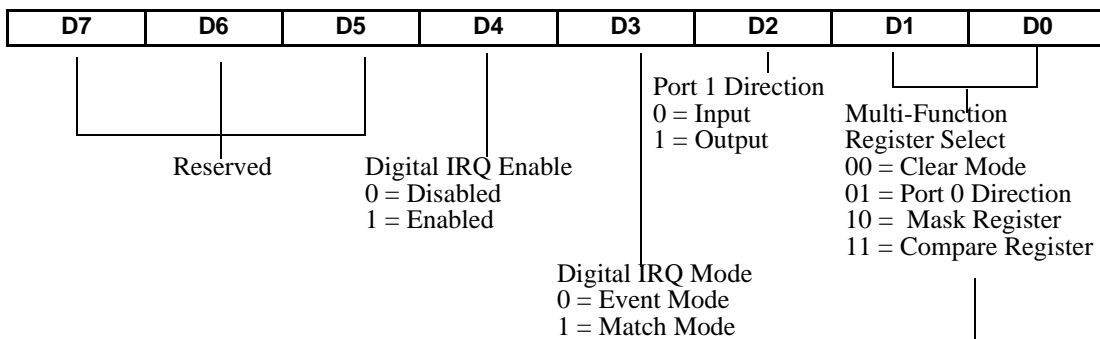

Multi-Function, at Address 452 Hex, Contents Based on Bits D0 and D1 of DIO-Control

		00 Clear	X	X	X	X	X	X	X
read/write		01 Port 0 Direction	I/O	I/O	I/O	I/O	I/O	I/O	I/O
0 in 1 out		10 DIO Mask	M7	M6	M5	M4	M3	M2	M1
0 no mask 1 mask		11 Compare	C7	C6	C5	C4	C3	C2	C0
read/write									

Clear Register:

A read to this register Clears the IRQs and a write to this register sets the DIO-Compare, DIO-Mask, DIO-Control, Port1 and Port0 to zeros. A write to this register is used to clear the board.

Port 0 Direction Register:

Writing a zero to a bit in this register makes the corresponding pin in the DIO connector an input. Writing a one to a bit in this register makes the corresponding pin in the DIO connector an output.

Mask Register:

Writing a zero to a bit in this register will not mask off the corresponding bit in the DIO-Compare register. Writing a one to a bit in this register masks off the corresponding bit in the DIO-Compare register. When all bits are masked off the DIOs comparator is disabled. This condition means Event and Match mode will not generate an interrupt. This register is used by Event and Match modes.

Compare Register:

A Read/Write register used for Match Mode. Bit values in this register that are not masked off are compared against the value on Port 0. A match or Event causes bit 6 of DIO-Control to be set and if the DIO is in Advanced interrupt mode, the Match or Event causes an interrupt.

Interrupts:

The Digital I/O can use interrupts 5, 7, 10, 11, and 12. The mapped interrupt numbers are 0x0D, 0x0F, 0x72, 0x73, and 0x74 in HEX respectfully or 13, 15, 114, 115, and 116 in decimal respectfully. To use any or all of the 5 listed interrupts set the interrupt(s) aside for an ISA legacy device. To set the interrupts aside enter the BIOS under PNP/PCI CONFIGURATION. Select Resources Controlled By and change the interrupt(s) you wish to use to Legacy ISA.

Advanced Digital Interrupts:

There are three advanced digital interrupt modes available. These three modes are Event, Match, and Strobe. The use of these three modes is to monitor state changes at the DIO connector. One way to enable interrupts is to set bit 4 of the DIO-Control register to an 1 and select Event or Match mode. The other way to enable interrupts will be explained in Strobe Mode.

Event Mode:

When this mode is enable, Port 0 is latched into the DIO-Compare register at 8.33 MHz. There is a deglitching circuit inside the DIO circuitry. The deglitching requires pulses on Port 0 to be at least 120 nanoseconds in width. As long as changes are present longer than that, the event is guaranteed to register. Pulses as small as 60 nanoseconds can register as an event but they must occur between the rising and falling edge of the 8.33 MHz clock. To enter Event mode, set bit 3 of the DIO-Control register to a zero.

Match Mode:

When this mode is enabled , Port 0 is latched into the DIO-Compare register at 8.33 MHz. There is a deglitching circuit inside the DIO circuitry. The deglitching requires pulses on Port 0 to be at least 120 nanoseconds in width. As long as changes are present longer than that, the match is guaranteed to register. Pulses as small as 60 nanoseconds can register as a match but they must occur between the rising and falling edge of the 8.33 MHz clock. To enter Match mode, set bit 3 of the DIO-Control register to a one. **!!Note!!** Make sure bit 3 is set BEFORE writing the DIO-Compare register. If you do not set bit 3 first, the contents of the DIO-Compare register could be lost. The reason for this is Event mode latches in Port 0 into the DIO-Compare register at an 8.33 MHz rate

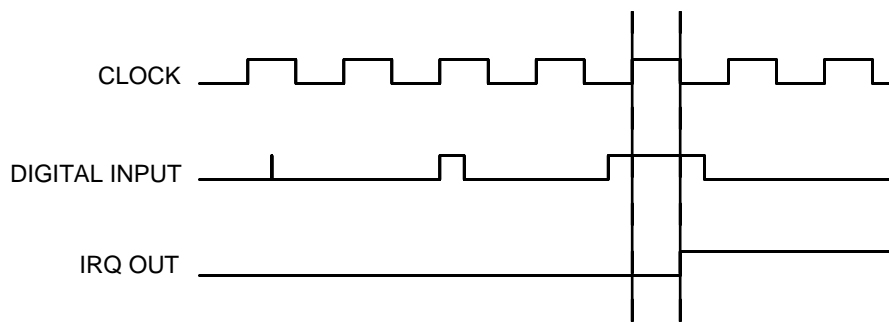

Strobe Mode:

There is another way to cause an interrupt is to write a **zero** to the Digital IRQ Enable bit of the DIO-Control register and write a **one** to the Digital IRQ Mode bit in the DIO-Control register. What these writes do is to allow the strobe pin of the DIO connector to trigger an interrupt. A low to high transition on the strobe pin will cause an interrupt request. The request will remain high until the Clear Register is read from. Additionally, the Compare Register latched in the value at Port 0 when the Strobe pin made a low to high transition. No further strobes will be available until a read of the Compare Register is made. What this implies is one must read the Compare Register then clear interrupts so that the latched value in the compare register is not lost.

Interrupt Generation

Digital IRQ Mode	Digital IRQ Enable	Function
0	0	DIO ONLY
0	1	Event Mode
1	0	Strobe Mode
1	1	Match Mode

Interrupt Selection:

The interrupt selection register is at I/O address 0x1F HEX. This is a 4 bit read/write register for selecting the IRQ used for the digital I/O. Setting the interrupt here actually connects the interrupt generating circuitry to the ISA bus. If you want to monitor interrupts on the bus, look at pins B23, B21, D3, D4, and D5 (see the description of the PC-104 connector).

Interrupt Select Register at I/O address 0x1F HEX

I1	I2	I3	I4
----	----	----	----

IRQ Select Values and Settings

Value BIN	IRQ Setting
X000	Disabled
X001	IRQ5
X010	IRQ7
X011	IRQ10
X100	IRQ11
X101	IRQ12
X110-X111	Reserved

Basic Interrupt Information for Programmers:

All information below only addresses the DIO on this board. Interrupts are connected to IRQs 5, 7, 10, 11, and 12 on the ISA bus (PC104 bus) and are controlled by two 8259-equivalent interrupt controllers containing 13 available interrupt request lines. Minimum time between two IRQ requests is 125 nanoseconds as set by ISA specification.

What is an Interrupt?

An interrupt is a subroutine called asynchronously by external hardware (usually an I/O device) during the execution of another application. The CPU halts execution of its current process by saving the system state and next instruction then jumps to the interrupt service routine, executes it, loads the saved system state and saved next instruction, and continues execution. Interrupts are good for handling infrequent events such as keyboard activity.

What happens when an Interrupt occurs?

An IRQ_x pin on the PC104 bus makes a low to high transition while the corresponding interrupt mask bit is unmasked and the PIC determines that the IRQ has priority, the PIC interrupts the processor. The current code segment (CS), instruction pointer (IP), and flags are pushed on the stack, the CPU reads the 8 bit vector number from the PIC and a new CS and IP are loaded from a vector, indicated by the vector number, from the interrupt vector table that exists in the lowest 1024 bytes of memory. The processor then begins executing instructions located at CS:IP. When the interrupt service routine is completed the CS, IP, and flags that were pushed onto the stack are popped from the stack into their appropriate registers and execution resumes from the point where it was interrupted.

How long does it take to respond to an interrupt?

A DOS operating system can respond to an interrupt between (6-15uS). A windows system can take a much longer time when a service routine has been installed by a device driver implemented as a DLL; from 250-1500uS or longer. A VxD will take 20-60uS or longer. The time the CPU spends in the interrupt is dependent on the efficiency of the code in the ISR. These numbers are general guidelines and will fluctuate depending on operating system and version. The amount of information that can be moved during an interrupt theoretically can be 4 MB\Sec on a 8 MB bus using the INS or MOVS instruction with the REP prefix. These instructions are in assembly language.

Interrupt Request Lines:

To allow different peripheral devices to generate interrupts on the same computer, the PC bus has eight different interrupt request (IRQ) lines. A transition from low to high on one of these lines generates an interrupt request which is handled by the PC's interrupt controller. The interrupt controller checks to see if interrupts are to be acknowledged from that IRQ and, if another interrupt is already in progress, it decides if the new request should supersede the one in progress or if it has to wait until the one in progress is done. This prioritizing allows an interrupt to be interrupted if the second request has a higher priority. The priority level is based on the number of the IRQ; IRQ0 has the highest priority, IRQ1 is second-highest, and so on through IRQ7, which has the lowest. Many of the IRQs are used by the standard system resources. IRQ0 is used by the system timer, IRQ1 is used by the keyboard, IRQ3 by COM2, IRQ4 by COM1, and IRQ6 by the disk drives. Therefore, it is important for you to know which IRQ lines are available in your system for use by the module.

8259 Programmable Interrupt Controller:

The chip responsible for handling interrupt requests in the PC is the 8259 Programmable Interrupt Controller. To use interrupts, you need to know how to read and set the 8259's interrupt mask register (IMR) and how to send the end-of-interrupt (EOI) command to the 8259.

Interrupt Mask Register (IMR):

Each bit in the interrupt mask register (IMR) contains the mask status of an IRQ line; bit 0 is for IRQ0, bit 1 is for IRQ1, and so on. If a bit is set (equal to 1), then the corresponding IRQ is masked and it will not generate an interrupt. If a bit is clear (equal to 0), then the corresponding IRQ is unmasked and can generate interrupts. The IMR is programmed through port 21H.

Writing an Interrupt Service Routine:

The first step in adding interrupts to your software is to write the interrupt service routine (ISR). This is the routine that will automatically be executed each time an interrupt request occurs on the specified IRQ. An ISR is different than standard routines that you write. First, on entrance, the processor registers should be pushed onto the stack BEFORE you do anything else. Second, just before exiting your ISR, you must clear the interrupt status flag of the DM5812 and write an end-of-interrupt command to the 8259 controller. Finally, when exiting the ISR, in addition to popping all the registers you pushed on entrance, you must use the IRET instruction and not a plain RET. The IRET automatically pops the flags, CS, and IP that were pushed when the interrupt was called.

If you find yourself intimidated by interrupt programming, take heart. Most C compilers allow you to identify a procedure (function) as an interrupt type and will automatically add these instructions to your ISR, with one important exception: most compilers do not automatically add the end-of-interrupt command to the procedure; you must do this yourself. Other than this and the few exceptions discussed below, you can write your ISR just like any other routine. It can call other functions and procedures in your program and it can access global data. If you are writing your first ISR, we recommend that you stick to the basics; just something that will convince you that it works, such as incrementing a global variable.

NOTE: If you are writing an ISR using assembly language, you are responsible for pushing and popping registers and using IRET instead of RET.

Writing a DOS Interrupt service routine (ISR):

There are a few cautions you must consider when writing your ISR. The most important is, do not use any DOS functions or routines that call DOS functions from within an ISR. DOS is not reentrant; that is, a DOS function cannot call itself. In typical programming, this will not happen because of the way DOS is written. But what about when using interrupts? Then, you could have a situation such as this in your program. If DOS function X is being executed when an interrupt occurs and the interrupt routine makes a call to DOS function X, then function X is essentially being called while it is already active. Such a reentrance attempt spells disaster because DOS functions are not written to support it. This is a complex concept and you do not need to understand it. Just make sure that you do not call any DOS functions from within your ISR. The one wrinkle is that, unfortunately, it is not obvious which library routines included with your compiler use DOS functions. A rule of thumb is that routines which write to the screen, or check the status of or read the keyboard, and any disk I/O routines use DOS and should be avoided in your ISR.

The same problem of reentrance exists for many floating point emulators as well, meaning you may have to avoid floating point (real) math in your ISR.

The Code:

Refer to the DOS drivers that were shipped with this board or download them from our web site www.rtd.com. The drivers are commented to help clarify their meaning. Reading through the DOS drivers will give valuable insight into the board functionality.

Advanced Level 2 Digital I/O (a2DIO)

The a2DIO provides an Advanced Digital I/O port with increased functionality. This port provides the same interrupt modes and bit direction programmable digital I/O as the aDIO. The a2DIO also provides a 16-bit Pulse Width Modulator (PWM), and an 8-bit Incremental Encoder. Because of the modularity of the a2DIO, custom designs are available. Please contact RTD Embedded Technologies for details.

Each of the 8 I/O pins of the a2DIO can be individually programmed as an input, output, or a peripheral output. A pin can always be used as a peripheral input. The peripherals are additional functions such as a Pulse Width Modulator or an Incremental Encoder. A Bus-Hold resistor is also provided on each pin, allowing the inputs to be left unconnected. The Bus-Hold will keep the input at its previous value until it is driven to a new value. A block diagram of the I/O ports is shown below:

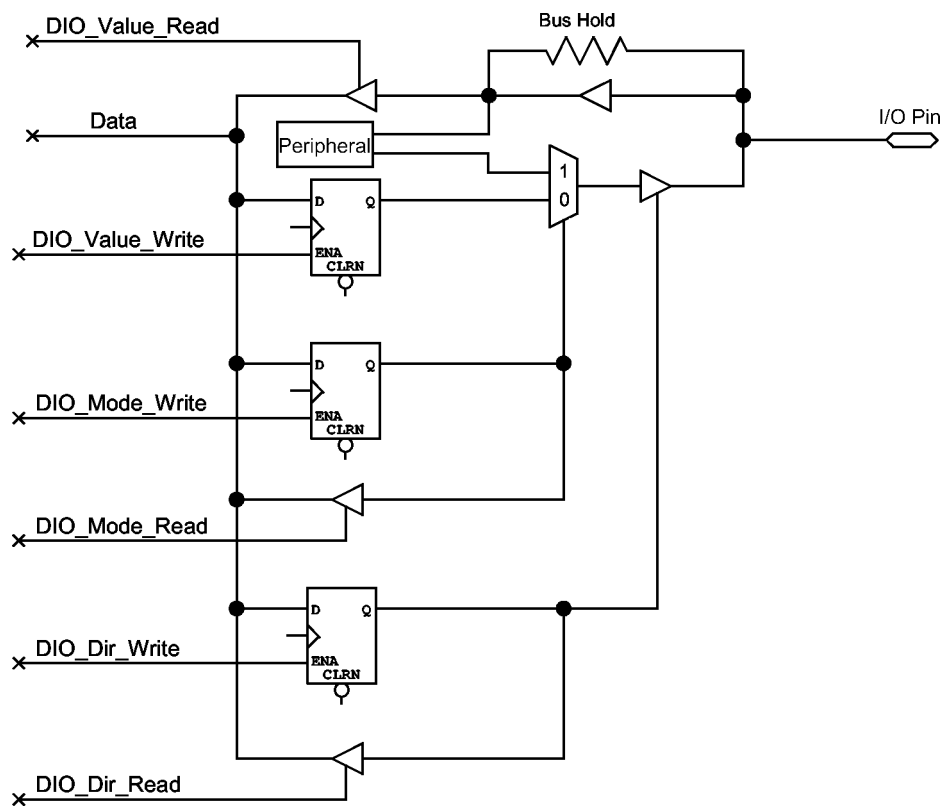

The following table shows how the peripherals map to the a2DIO pins.

Peripheral Pin Map

Pin	Peripheral Input (DIO_Dir[n]='0', DIO_Mode[n]='X')	Peripheral Output (DIO_Dir[n]='1', DIO_Mode[n]='1')
a2D0	-	PWM_Plus
a2D1	-	PWM_Minus
a2D2	-	-
a2D3	-	-
a2D4	Inc_Enc_A	-
a2D5	Inc_Enc_B	-
a2D6	Inc_Enc_Clr	-
a2D7	-	-

There are two regions in I/O space that are used by the a2DIO; the Control Registers and the Runtime Registers. The Control Registers are used to enable the a2DIO, set the base address of the Runtime Registers, and set the IRQ line. These registers are generally set by the BIOS, and are read by the DOS drivers to determine the base address and interrupt to use. The Runtime Registers are used by the drivers to operate the various features of the a2DIO.

Control Register Descriptions

The Control Registers are fixed at I/O address 0x30 and 0x31. The register map of the a2DIO Control Registers is shown below:

a2DIO-Control I/O address 0x30 HEX

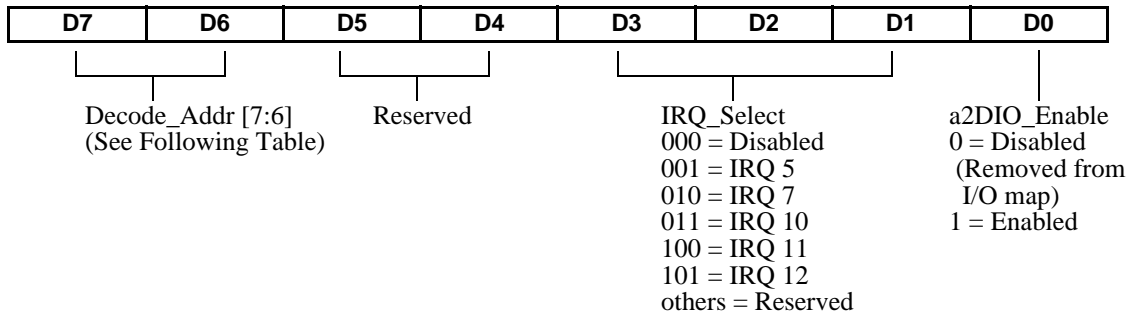

a2DIO-Control I/O address 0x31 HEX

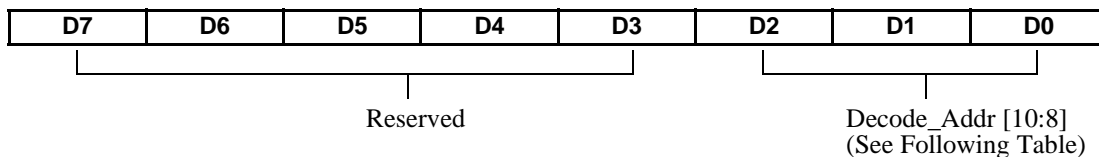

The base address of the Runtime Registers is determined by the value of Decode_Addr[10:6]. The user can access the Runtime Registers when Decode_Addr[10:6] match I/O address bits [10:6]. An abbreviated table of the base addresses for the Runtime Registers is shown below.

Base Address Decode Assignments

Decode_Addr [10:6]	Base Address
00000	0x000
00001	0x040
00010	0x080
...	...
01100	0x300
01101	0x340
01110	0x380
01111	0x3C0
10000	0x400
10001	0x440
10010	0x480
10011	0x4C0
...	...
11110	0x780
11111	0x7C0

Runtime Register Descriptions

The second region in I/O space that is occupied by the a2DIO is the Runtime Registers. The location of this region is set by the Decode_Addr value in the a2DIO-Control registers. The register map for the runtime region is shown below:

a2DIO Runtime Registers

Offset	Register Name	Description
0x00	Int_Stat	Interrupt Status / Clear Register
0x01	Int_Enable	Interrupt Enable Register
0x02 - 0x06	Reserved	Reserved
0x07	a2DIO_Ver	Version Register
0x08	DIO_Value	DIO Value Register
0x09	DIO_Dir	DIO Direction Register
0x0A	DIO_Mode	DIO Mode Register
0x0B	DIO_Compare	DIO Compare / Latch Register
0x0C	DIO_Mask	DIO Mask Register
0x0D - 0x0E	Reserved	Reserved
0x0F	DIO_Control	DIO Control Register
0x10	IE_Value_L	Incremental Encoder Value Register
0x11 - 0x12	Reserved	Reserved
0x13	IE_Control	Incremental Encoder Control Register
0x14 - 0x17	Reserved	Reserved
0x18	PWM_Width_L	PWM Width Low Byte
0x19	PWM_Width_H	PWM Width High Byte
0x1A	PWM_Period_L	PWM Period Low Byte
0x1B	PWM_Period_H	PWM Period High Byte
0x1C - 0x1E	Reserved	Reserved
0x1F	PWM_Control	PWM Control Register

The Runtime Registers are separated into several function blocks; Global, Digital I/O, Incremental Encoder, and PWM. The following sections describes each of the Runtime Registers in detail.

In the following register description sections, each register is described by a register table. The first row of the table list the bits, D7 through D0. The second row lists the field name for each bit. The third row lists the properties of that bit; 'r' = bit can be read, 'w' = bit can be written to, and 'c' = bit can be cleared. The last row lists the value of the bit after reset. The register table is then followed by a description of each of the fields where applicable. An "N/A" for the reset value indicates that the reset value is not applicable - read the field descriptions for more information.

Bits marked as "Reserved" in the field name are unused, and reads will always return their reset value. These bit should be set to '0' during writes for future compatability.

Global Function Block

The Global Function Block contains the logic that affects the entire a2DIO. This includes the interrupt status register, interrupt enable register, and the version register.

Interrupt Status / Clear Register

The Interrupt Status register shows the status of the various interrupt sources, or interrupt events, for the a2DIO. Each bit is set to '1' when it's corresponding event occurs, and remains set until cleared by the user. A bit is cleared (set to '0') by writing a '1' to it. Writing a '0' has no effect.

If an interrupt occurs on the board while another is pending, the Int_Stat register will be updated, but a second interrupt will not be generated. For example, if a PWM interrupt occurs, and then a DIO interrupt occurs before the Interrupt Service Routine (ISR) clears the PWM interrupt, the Int_Stat register will show the PWM and DIO bits set to '1', but only one interrupt will be generated to the CPU. Because of this, the ISR should clear the Int_Stat register as quickly as possible, or should check for additional interrupts before exiting.

An interrupt is only generated when the event is enabled in the specific function block, AND the appropriate bit in the Int_Mask register is set. The interrupt line must also be properly set in the a2DIO_Control register (in the BIOS Setup). The circuit shown below describes how the a2DIO generates an interrupt. The interrupt source and function block control register are only shown for the PWM. There is similar logic for the Incremental Encoder and DIO

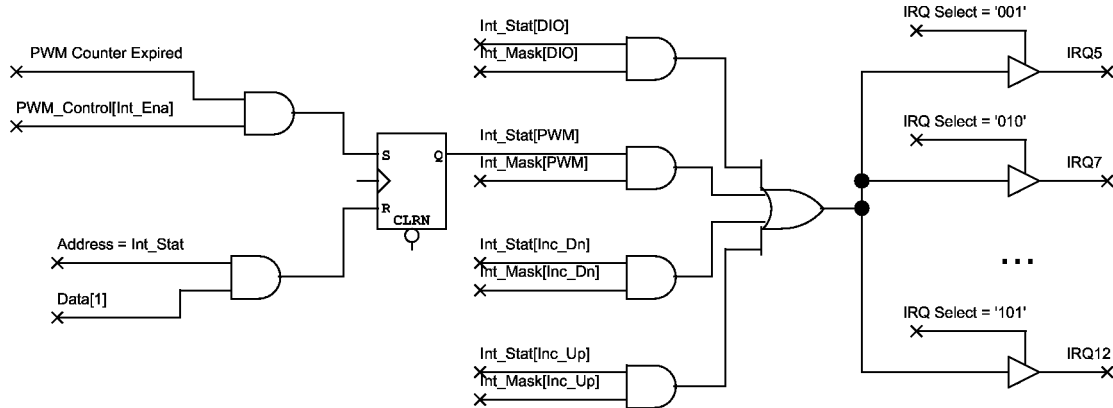

As an example, to use the PWM interrupt:

- 1) a2DIO_Control[IRQ Select] must be set to a valid interrupt (select in the BIOS setup).
- 2) The interrupt line must be configured properly in the PIC.
- 3) PWM_Control[IRQ] must be set to '1'.
- 4) Int_Enable[PWM] must be set to '1'.

Int_Stat

D7	D6	D5	D4	D3	D2	D1	D0
Reserved	Reserved	Reserved	Reserved	Inc_Up	Inc_Dn	PWM	DIO
r	r	r	r	r/c	r/c	r/c	r/c
0	0	0	0	0	0	0	0

Inc_Up Incremental Encoder "Carry Up" interrupt. This bit is cleared by writing a '1' to it.

Inc_Dn Incremental Encoder "Carry Down" interrupt. This bit is cleared by writing a '1' to it.

PWM This bit is set when the PWM counter expires. This bit is cleared by writing a '1' to it.

DIO This bit is set when a digital I/O interrupt is generated. See the DIO_Control section for more details. This bit is cleared by writing a '1' to it.

Interrupt Enable Register

Int_Enable

D7	D6	D5	D4	D3	D2	D1	D0
Reserved	Reserved	Reserved	Reserved	Inc_Up	Inc_Dn	PWM	DIO
r	r	r	r	r/w	r/w	r/w	r/w
0	0	0	0	0	0	0	0

Inc_Up Set this bit to '1' to enable the Inc_Up interrupt. Set to '0' to disable.

Inc_Dn Set this bit to '1' to enable the Inc_Dn interrupt. Set to '0' to disable.

PWM Set this bit to '1' to enable the PWM interrupt. Set to '0' to disable.

DIO Set this bit to '1' to enable the DIO interrupt. Set to '0' to disable.

Version Register

a2DIO_Ver

D7	D0
a2DIO_Ver	
r	
N/A	

a2DIO_Ver The version of the a2DIO Firmware.

Digital I/O Function Block

The Digital I/O Function Block provides the user interface to the programmable digital I/O and Advanced Digital Interrupts. These registers are used to configure each pin as an input, output, or peripheral output, and control the value on the pins. This block also includes the Match and Mask registers for Advanced Interrupt Mode.

DIO Value Register

DIO_Value

D7	D6	D5	D4	D3	D2	D1	D0
a2D7	a2D6	a2D5	a2D4	a2D3	a2D2	a2D1	a2D0
r/w	r/w	r/w	r/w	r/w	r/w	r/w	r/w
0	0	0	0	0	0	0	0

a2D[7:0] Read or write the value of an a2DIO pin. Reads will always return the value of the pin. Writes will set the value of the pin if it is set to an output (DIO_Dir[n]=1) and set as a digital I/O (DIO_Mode[n]=1). Otherwise, the value that is written is stored, and will be sent to the pin when those two conditions become true.

DIO Direction Register

DIO_Dir

D7	D6	D5	D4	D3	D2	D1	D0
a2D7	a2D6	a2D5	a2D4	a2D3	a2D2	a2D1	a2D0
r/w	r/w	r/w	r/w	r/w	r/w	r/w	r/w
0	0	0	0	0	0	0	0

a2D[7:0] Sets the direction of a pin. The pin is an output when the bit is set to '1', and an input when the bit is '0'. Note that this also controls the direction of the pin in peripheral mode, i.e. the PWM on pin a2D0 will only output when DIO_Dir[a2D0] = '1'.

DIO Mode Register

DIO_Mode

D7	D6	D5	D4	D3	D2	D1	D0
a2D7	a2D6	a2D5	a2D4	a2D3	a2D2	a2D1	a2D0
r	r	r	r	r	r	r/w	r/w
0	0	0	0	0	0	0	0

a2D[7:0] Selects between digital I/O and peripheral output for the specified pins. The pin is a digital I/O when DIO_Mode[n] = '0', and a peripheral output when DIO_Mode[n] = '1'. Note that not all of the pins have an associated peripheral output.

DIO Compare / Latch Register

DIO_Compare

D7	D0
DIO_Compare	
r/(w)	
0x00	

DIO_Compare This register has several functions depending on the value of DIO_Control[Int_Mode]. The table below describes these functions. See the section on Advanced Interrupts for more information.

Int_Mode	DIO_Compare Description	Read/Write
00 (Disabled)	Has no function.	r/w
01 (Strobe)	The value in DIO_Value is latched into the DIO_Compare register at the positive edge of the Strobe.	r
10 (Match)	The value in DIO_Compare is compared with the current value of DIO_Value, and an interrupt is generated when they match.	r/w
11 (Event)	The value in DIO_Value is copied into DIO_Compare, and an interrupt is generated when it changes.	r

DIO Mask Register

DIO_Mask

D7	D6	D5	D4	D3	D2	D1	D0
a2D7	a2D6	a2D5	a2D4	a2D3	a2D2	a2D1	a2D0
r/w	r/w	r/w	r/w	r/w	r/w	r/w	r/w
0	0	0	0	0	0	0	0

a2D[7:0] This register has several functions depending on the value of DIO_Control[Int_Mode]. The table below describes these functions. See the section on Advanced Interrupts for more information.

Int_Mode	DIO_Mask Description
00 (Disabled) or 01 (Strobe)	When DIO_Value is written to, if DIO_Mask[n] is set to '1', DIO_Value[n] will not change.
10 (Match) or 11 (Event)	When DIO_Mask[n] is set to '1', the corresponding bit in the DIO_Compare register is masked, i.e. that bit becomes a "don't care."

DIO Control Register

DIO_Control

D7	D6	D5	D4	D3	D2	D1	D0
Strobe	Reserved	Reserved	Reserved	Clk_Mode	Int_Mode		Clear
r	r	r	r	r/w	r/w		r/w
N/A	0	0	0	0	0		0

Strobe This is the read-only value of the a2Str pin.

Clk_Mode When set to '0', a 33 MHz clock is used to qualify the Match and Event interrupts. When set to '1', the a2Str pin is used as a clock for Match and Event interrupts.

Int_Mode Sets the interrupt mode as follows:

Int_Mode	DIO_Control[Int_Mode] Description
00	Interrupt Disabled
01	Interrupt on Strobe - an interrupt is generated on the positive edge of the a2Str signal.
10	Interrupt on Match - an interrupt is generated when DIO_Value matches DIO_Compare (qualified by DIO_Mask and the clock selected by DIO_Control[Clk_Mode])
11	Interrupt on Event - an interrupt is generated when DIO_Value changes (qualified by DIO_Mask and the clock selected by DIO_Control[Clk_Mode])

Clear The DIO function block is cleared when this bit is set to '1'. This bit must be manually cleared.

Advanced Digital Interrupts

The a2DIO provides Advanced Digital Interrupt modes. The three modes are match, event, and strobe. Match mode generates an interrupt when an eight bit pattern is received in parallel that matches the DIO_Match register. The event mode generates an interrupt when a change occurs on any bit. In either mode, masking can be used to ignore selected lines.

These modes are further enhanced by the ability to use the external strobe (a2Str) as a clock. When the strobe is selected as the clock source, an interrupt will only occur if the above condition is met, AND there is a rising edge on the strobe.

In strobe mode, an interrupt is generated at every rising edge of the strobe. In this mode, the value of the I/O pins is also stored in the DIO_Compare register at the rising edge of the strobe.

An interrupt will only occur at the onset of the event. For example, suppose an interrupt occurs in Compare mode. After the ISR clears the interrupt in Int_Stat, the interrupt will not be generated again if DIO_Value continues to match DIO_Compare. The bit in Int_Stat remains cleared. The interrupt will only occur again if DIO_Value and DIO_Compare do not match, and then match again.

Incremental Encoder Function Block

The Incremental Encoder Function Block provides an 8 bit counter that is incremented or decremented based on the Inc_Enc_A and Inc_Enc_B signals. The counter can be cleared externally, and can provide an interrupt when the counter rolls over.

In order to read the value of the counter, IE_Control[Hold] should first be set to '0' to be sure the value is current, then set to '1' to prevent the value in IE_Value from changing. The IE_Value register can then be read. The actual count continues in the background, and IE_Value is updated again when IE_Control[Hold] = '0'. If this procedure is not followed, the IE_Value could change during the read operation, causing an incorrect value to be returned.

The Incremental Encoder provides both a "Carry Up" and a "Carry Down" interrupt. The IE_Control[Int_Ena] bit must be set to '1' for either of these interrupts to be enabled. The "Carry Up" interrupt is the Int_Stat[Inc_Up] bit. This bit is set to '1' when the incremental encoder has a value of 0xFF and receives a signal to count up. The "Carry Down" interrupt is the Int_Stat[Inc_Dn] bit. This bit is set to '1' when the incremental encoder has a value of 0x00 and received a signal to count down. It is also set when the incremental encoder is cleared externally while it receives a signal to count down. These interrupts allow the application software to expand the width of the counter to any value. The Interrupt Service Routine can adjust the value of a variable based on the Int_Stat register, allowing any width of counter.

The Incremental Encoder provides two modes of operation, Quadrature Mode and Pulse Count Mode. In Pulse Count mode, positive edges on the Inc_Enc_A input increase the counter, and positive edges on Inc_Enc_B decrease the counter. Quadrature Mode is designed to be used with industry standard Incremental Encoders. A diagram of its operation is shown below.

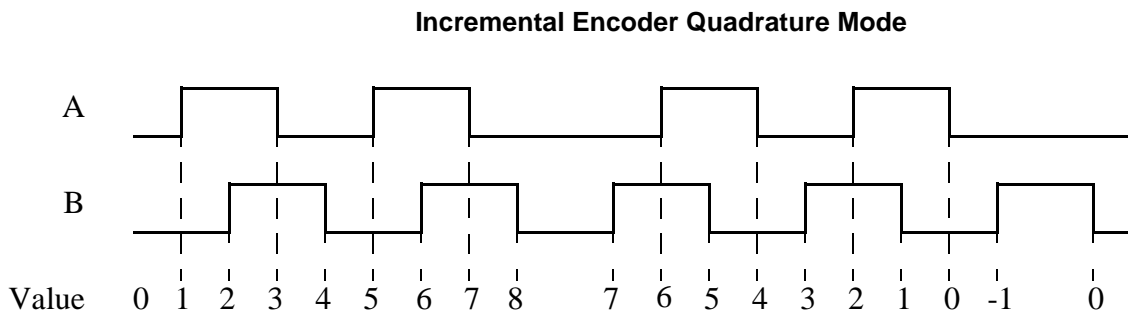

Incremental Encoder Value Register

IE_Value

D7	D0
IE_Value	
r/(w)	
0x00	

IE_Value This register contains the value of the incremental encoder. This register can be written to when IE_Control[Enable] = '0'. Note that when IE_Control[Hold]='0', this register may change during reads, resulting in an erroneous value.

Incremental Encoder Control Register

IE_Control

D7	D6	D5	D4	D3	D2	D1	D0
Reserved	Clk_Mode	IEMode	Ext_Clr	Int_Ena	Hold	Enable	Clear
r	r/w	r/w	r/w	r/w	r/w	r/w	r/w
0	0	0	0	0	0	0	0

Clk_Mode When set to '0', an 8 MHz clock is used. When set to '1', a 33 MHz clock is used. An 8 MHz clock should be used in noisy environments with count rates up to 4 MHz. A 33 MHz clock can be used with a count rate up to 16 MHz.

IEMode When set to '0', the Incremental Encoder operates in Quadrature Mode. When set to '1', the Incremental Encoder operates in Pulse Count Mode.

Ext_Clr When set to '0', external clear is disabled. When set to '1', the counter is cleared when the Inc_Enc_Clr input is high.

Int_Ena When set to '0', the Incremental encoder interrupts are disabled. When set to '1', the incremental encoder interrupts are enabled. An interrupt is provided for both carry up and carry down.

Hold When set to '0', the value in IE_Value is always the value of the encoder counter. When set to '1', the value in IE_Value is held, while the encoder counter is counting in the background.

Enable When set to '0', the incremental encoder will not count. When set to '1', the incremental encoder is enabled.

Clear The Incremental Encoder function block is cleared when this bit is set to '1'. This bit must be manually cleared.

Pulse Width Modulator Function Block

The Pulse Width Modulator will generate an output with an adjustable width and period. The PWM can generate both a positive (PWM_Plus) and a negative (PWM_Minus) output. In order for the PWM outputs to drive a pin, the appropriate bits in DIO_Mode and DIO_Dir must be set (see those sections for details, as well as the Peripheral Pin Map). The positive output will always be zero when PWM_Width is zero, and always high when PWM_Width is at its maximum value. The negative output is the inverse of the positive output, i.e. high when PWM_Width is zero and low when PWM_Width is at its maximum. The positive and negative outputs are both at zero when the PWM is disabled (PWM_Control[Enable] = '0').

The PWM is based on a 33 MHz clock, so the PWM_Period and PWM_Width registers have a 30ns resolution. The value in PWM_Width is how many clock cycles the positive output is high. The period in clock cycles is the value in PWM_Period + 2. Note that with PWM_Period set to 0xFFFF or greater, a duty cycle of 100% is not possible. Also, when PWM_Period is set to 0xFFFF, a non-zero value in PWM_Width results in a width of PWM_Width + 1 cycles. The diagram below illustrates the PWM cycle.

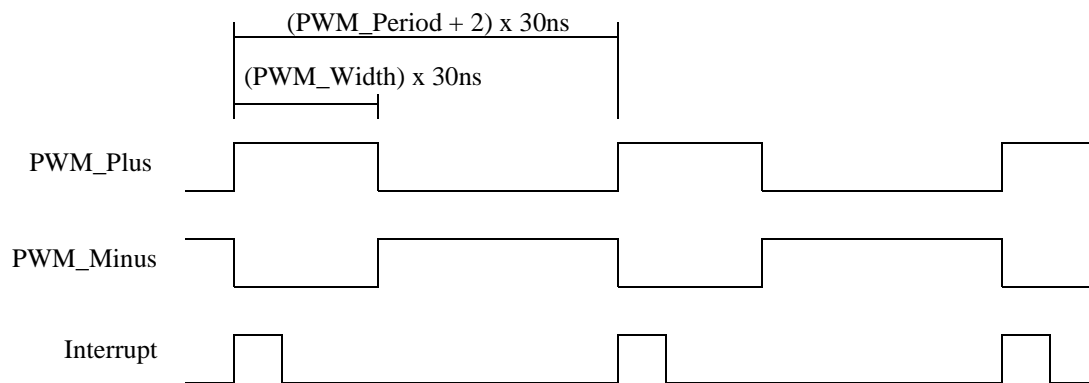

The width of the PWM is updated after the lower byte (PWM_Width_L) is written to, and the period expires. Therefore, the PWM_Width registers can be written to at any time, as long as the PWM_Width_L register is written to last. The Period registers are updated as soon as the register is written to. Unpredictable results may occur if the PWM_Period registers are modified while the PWM is enabled.

An interrupt can be generated whenever the PWM Period expires. This interrupt can be used to load a new value into the PWM_Width registers, or as a periodic interrupt. The interrupt is generated regardless of whether the PWM outputs are enabled, so this function block can be used to generate a periodic interrupt without using it as a PWM. Note that an interrupt may also be generated as soon as the PWM is enabled.

PWM Width Register

PWM_Width_L

D7	D0
PWM_Width[7:0]	
r/w	
0x00	

PWM_Width_H

D7	D0
PWM_Width[15:8]	
r/w	
0x00	

PWM_Width This register controls the width of the PWM Pulse. This is the width of the positive section of the PWM_Plus output, or the negative section of the PWM_Minus output. Each unit has a value of 30 ns.

PWM Period Register

PWM_Period_L

D7	D0
PWM_Period[7:0]	
r/w	
0x00	

PWM_Period_H

D7	D0
PWM_Period[15:8]	
r/w	
0x00	

PWM_Period This register controls the period, or frequency of the PWM Pulse. The actual period is $(\text{PWM_Period} + 2) \times 30$ ns. If $\text{PWM_Period} = 0\text{xFFFF}$, the output will have a width of $\text{PWM_Width} + 1$.

PWM Control Register

PWM_Control

D7	D4	D3	D2	D1	D0
Reserved		Int_Ena	Reserved	Enable	Clear
r		r/w	r	r/w	r/w
0x0		0	0	0	0

- Int_Ena When set to '0', the PWM interrupt is disabled. When set to '1', the PWM interrupt is enabled. An interrupt is generated every time PWM_Period expires.
- Enable When set to '0', the PWM will not count, and both outputs are at '0'. When set to '1', the PWM is enabled.
- Clear The PWM function block is cleared when this bit is set to '1'. This bit must be manually cleared.

Watchdog Timer Control

The cpuModule includes a Watchdog Timer, which provides protection against programs "hanging", or getting stuck in an execution loop where they cannot respond correctly. When enabled, the Watchdog Timer must be periodically reset by your application program. If it is not reset before the time-out period of 1.2 seconds expires, it will cause a hardware reset of the cpuModule.

Three functions have been implemented on the cpuModule for Watchdog Timer control. These are:

- Watchdog Timer enable
- Watchdog Timer disable
- Watchdog Timer reset

To enable the watchdog timer you must write a 1 to Bit 0 of I/O register 1Eh. To ensure compatibility with future designs, you should read the register and only change the bit you need to change.

After you enable the watchdog timer, you must reset it at least once every 1.2 seconds by reading I/O 1Eh. The data read does not matter.

To disable the watchdog timer you must write a 0 to Bit 0 of I/O register 1Eh.

Enabling the watchdog timer is illustrated in the following QuickBasic program fragment:

```
temp = INP(&H1E)      'Read I/O port 1Eh
temp = temp OR 1      'Set LSB to 1
OUTPUT &H1E, temp     'Enable WDT
```

When the watchdog timer is enabled it must be refreshed before it times out or it hardware reset the system. Refreshing the watchdog timer is illustrated in the following QuickBasic program fragment:

```
temp = INP(&H1E)      'Read I/O port 1Eh to refresh the WDT
```

Disabling the watchdog timer is illustrated in the following QuickBasic program fragment:

```
temp = INP(&H1E)      'Read I/O port 1Eh
temp = temp AND &HFE  'Clear LSB to 0
OUTPUT &H1E, temp     'Disable WDT
```

Real Time Clock Control

The cpuModule is equipped with a Real Time Clock (RTC) which provides system date and time functions, and also provides 128 non-volatile memory locations. The contents of these memory locations are retained whenever an external backup battery is connected, whether or not system power is connected.

You may access the RTC date, time, and memory using an index and data register at I/O addresses 70h and 71h. Address 70h is the Index register. It must be written with the number of the register to read or write. Refer to the map below for valid choices for the index. Data is then written to or read from the selected register by writing or reading (respectively) the data register at address 71h.

	<p>Do <i>not</i> change values stored in the RTC registers listed as RESERVED in the table below. Doing so will interfere with proper cpuModule operation.</p>
---	--

Registers of the Real Time Clock are shown below.:

Real Time Clock Registers			
Registers (hex)	Registers (decimal)	Number of Bytes	Function
00h	0	1	BCD Seconds
02h	2	1	BCD Minutes
04h	4	1	BCD Hours
06h	6	1	Day of week
07h	7	1	Day of month
08h	8	1	Month
09h	9	1	Year
0A-31h	10-49	40	RESERVED- Do not modify!
32h	50	1	BCD Century
33-3Fh	51-63	13	RESERVED - Do not modify!
40-7Fh	64-127	64	User RAM

RTC access is illustrated in the following QuickBasic program fragment:

Reference APP note ANC114 at <http://www.rtd.com/appnote/ANC114.pdf>

Processor Clock Control

The processor clock is controller by solder jumpers on the board. These are set at the factory and should not be adjusted.

Please see *Power Consumption* for a listing of Power Consumption.

Storing Applications On-board

The cpuModule was designed to be used in embedded computing applications. In these applications, magnetic media like hard disks and floppy disks are not very desirable. It is better to eliminate magnetic storage devices and place your operating system and application software into the cpuModule's Solid State Disk (SSD).

The following section describes two distinctly different ways you may use the Solid State Disk sockets of the cpuModule. These methods allows you to use a wide variety of memory devices to implement on-board Solid State Disk storage, each with its advantages and disadvantages.

Ways to Use the Solid State Disk Socket

The ways to utilize the Solid State Disk socket of the cpuModule.

- Using a device which installs as a BIOS Extension
- Using Conventional SSD Memory

BIOS Extension Devices such as DiskOnChip® and PromDisk provide a relatively large amount of read/write disk space. These devices generally appear similar to a conventional hard disk to DOS, allowing you to copy, delete, and rename files without using any special utilities.

Conventional Solid State Disk can use a variety of memory devices, such as:

- Atmel 5 volt only Flash
- Intel 12 volt Flash
- AMD 5-volt Flash
- Static RAM
- NOVRAM
- EPROM

to create a Solid State Disk. When used with Atmel 5 volt Flash, SRAM, or NOVRAM, the SSD appears similar to a read/write floppy disk to DOS, allowing you to copy, delete, and rename files in the SSD without using any special utilities.

When used with other Flash or EPROM, you can create file to program the device with the RIMAGE program.

These methods are described in detail in the following sections.

Using BIOS Extension Devices

You can use BIOS Extension Devices like M-Systems DiskOnChip® and MCSI PromDisk to implement a Solid State Disk which can be read and written using normal disk commands.

Advantages of using these devices include:

- Storage capacity up to 1 GB per socket (more in the future)
- Full read/write capability using standard OS file commands
- Integrated support for other operating systems is possible (contact M-Systems for information)

Parts supported by the cpuModule include:

- M-Systems 2000 series: MD2203-D1024 (1 GB)
down to...16 MB
- Optional alternate operating system versions of the above parts
- MCSI PromDisk: 72300 (4MB)
- MCSI PromDisk: 72301 (8MB)

Our website at www.rtd.com provides links to the websites of these manufacturers.

Installing BIOS Extension Devices

To install these devices, follow this procedure:

- Apply power to the cpuModule and run Setup.
- Set A BIOS Extension Window on the advanced setup page. .

NOTE!	The memory window selected for a BIOS extension device must not be used by any other program or hardware device. Make sure this window is not used by EMM386 or another memory manager, Ethernet card, PCMCIA card, etc.
--------------	--

- Save your changes and exit Setup.
- Turn off the cpuModule.
- Install the BIOS Extension Device into the socket.
- Reboot the cpuModule. The BIOS Extension Device should appear as the next available hard drive in your system. If there is no other hard drive installed, it will appear as drive C:.
- Format the new drive using the DOS format command.

NOTE!	If you wish to make the drive bootable, you must format it using the /s switch of the format command. Refer to your OS manual for more information.
--------------	---

- If you wish to boot from the BIOS Extension Device, run Setup and disable any other hard drive. Set the boot device to Hard Drive. The cpuModule will not boot to a BIOS Extension Device if another hard drive is enabled.

Using Conventional Solid State Devices

You can use numerous memory types to implement a Conventional Solid State Disk. Depending on the devices used, you may implement read/write, read-only, or write-once-read-many type drives.

Advantages of using the Conventional SSD include:

- Storage capacity up to 1 MB (EPROM only)
- Atmel Flash and NovRAM allow read/write capability using standard DOS file commands

Disadvantages of using the Conventional SSD include:

- Requires external utility program and device programmer to program 12 volt Flash, AMD 5-volt Flash, or EPROM.
- Limited memory size.

The following memory devices or their equivalents may be used for a Conventional SSD. Access times for all devices must be 150 ns or less, and all devices *must* be in 32-pin DIP packages.

- Atmel 29C010A, 29C020A or 29C040A
- +12 V Flash 28F010, 28F020
- +5 V Flash 29F010, 29F040
- SRAM 128Kx8, 512Kx8
- NOVRAM (Dallas Semiconductor DS1645Y, DS1650Y)
- EPROM (27C010, 27C020, 27C040, 27C080)

Installing a Conventional SSD using Atmel 5-volt-only Flash

To install an SSD using Atmel Flash, follow this procedure:

- Apply power to the cpuModule and run Setup.
- Set **SSD socket 1** to the appropriate Atmel device type.
- Set **SSD Window** to a value which will not conflict with other hardware or software.

NOTE! The memory window selected for DOC must not be used by any other program or hardware device. Make sure this window is not in use by EMM386 or another memory manager, or an Ethernet card, PCMCIA card, etc.

- Save your changes and exit Setup.
- Turn off the cpuModule.
- Install the memory device into the socket.
- Reboot the cpuModule. The SSD should appear as the next available drive in your system.

- Format the SSD using the DOS format command.

NOTE! If you wish to make the SSD bootable, you must format it using the /s switch of the format command. Refer to your DOS manual for more information on format.

When using the MS-DOS format command, always specify a size parameter. Use a size larger than the installed SSD, e.g.

format /f:1.44M (for 2 x 512K Atmel Flash devices)

- If you wish to boot from the SSD make it diskette A.

Installing a Conventional SSD using SRAM or NOVRAM

When the Solid State Disk is composed of SRAM or NOVRAM, it appears as a read/write disk and may be read and written using normal DOS disk commands.

To install an SRAM or NOVRAM SSD, you should follow this procedure:

- Apply power to the cpuModule and run Setup.
- Set **SSD socket 1 or 2** to the appropriate SRAM or NOVRAM device type.
- Set **SSD Window** to a value which will not conflict with other hardware or software.

NOTE! The memory window selected for DOC must not be used by any other program or hardware device. Make sure this window is not in use by EMM386 or another memory manager, or an Ethernet card, PCMCIA card, etc.

- Save your changes and exit Setup.
- Turn off the cpuModule.
- Install the memory device into the cpuModule socket.
- Reboot the cpuModule. The SSD should appear as the next available drive in your system.
- Format the SSD using the DOS format command.

If you wish to make the SSD bootable, you must format it using the /s switch of the format command. Refer to your DOS manual for more information on the format command.

If you wish to boot from the SSD make it diskette A.

Notes on Formatting an SRAM or NOVRAM SSD

For most purposes, you can format the SRAM or NOVRAM SSD as you would a 1.44MB floppy, using a command line similar to:

for example *format b: /u*

To get the most possible space in the disk and ensure proper operation, use the format command with a size parameter just over the total size of the installed SSD memory. For example, if you install 256 Kbytes of SRAM, you should use format with the parameters for a 360 Kbyte floppy disk. For example:

ROM-DOS™:format b: /u /n:9 /t:40

MS-DOS:format b: /f:360K

See your DOS manual for details on the format command and its parameters.

Installing a Conventional SSD using EPROM or Flash other than Atmel

EPROMs or Flash EPROMs for an SSD must be programmed externally to the cpuModule, using an EPROM programmer and following the procedure below.

To install an EPROM SSD, you should follow this procedure:

- Apply power to the cpuModule and run Setup.
- Set **SSD socket 1 or 2** to the appropriate EPROM or Flash type.
- Set **SSD Window** to a value which will not conflict with other hardware or software.

NOTE! The memory window selected for DOC must not be used by any other program or hardware device. Make sure this window is not in use by EMM386 or another memory manager, or an Ethernet card, PCMCIA card, etc.

- Save your changes and exit Setup.
- Boot the cpuModule.

After booting, the Solid State Disk will be seen by the system as a write-protected floppy. DOS commands normally used to read floppy disks will work with the SSD.

Directly Accessing the Solid State Disk

If you wish to directly access the Solid State Disk of the cpuModule contact the factory for additional information on doing so.

CHAPTER 6: HARDWARE REFERENCE

This appendix gives information on the cpuModule hardware, including:

- jumper settings and locations
- mechanical dimensions
- processor thermal management

Jumpers

Many cpuModule options are configured by positioning jumpers. Jumpers are labeled on the board as “**JP**” followed by a number.

Some jumpers are three pins, allowing three settings:

- pins 1 and 2 connected (indicated as "1-2")
- pins 2 and 3 connected (indicated as "2-3")
- no pins connected.

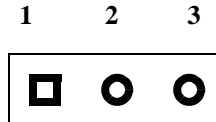

Some jumpers are two-pin, allowing two settings:

- pins 1 and 2 connected (indicated as "closed")
- pins 1 and 2 un-connected (indicated as "open")

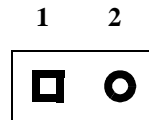

The figure below shows the locations of the jumpers used to configure the cpuModule. To use the figure, position the module with the PC/104 bus connector at the six o'clock position and the component side facing up. The table below lists the jumpers and their settings.

CML27686HX Connector Locations

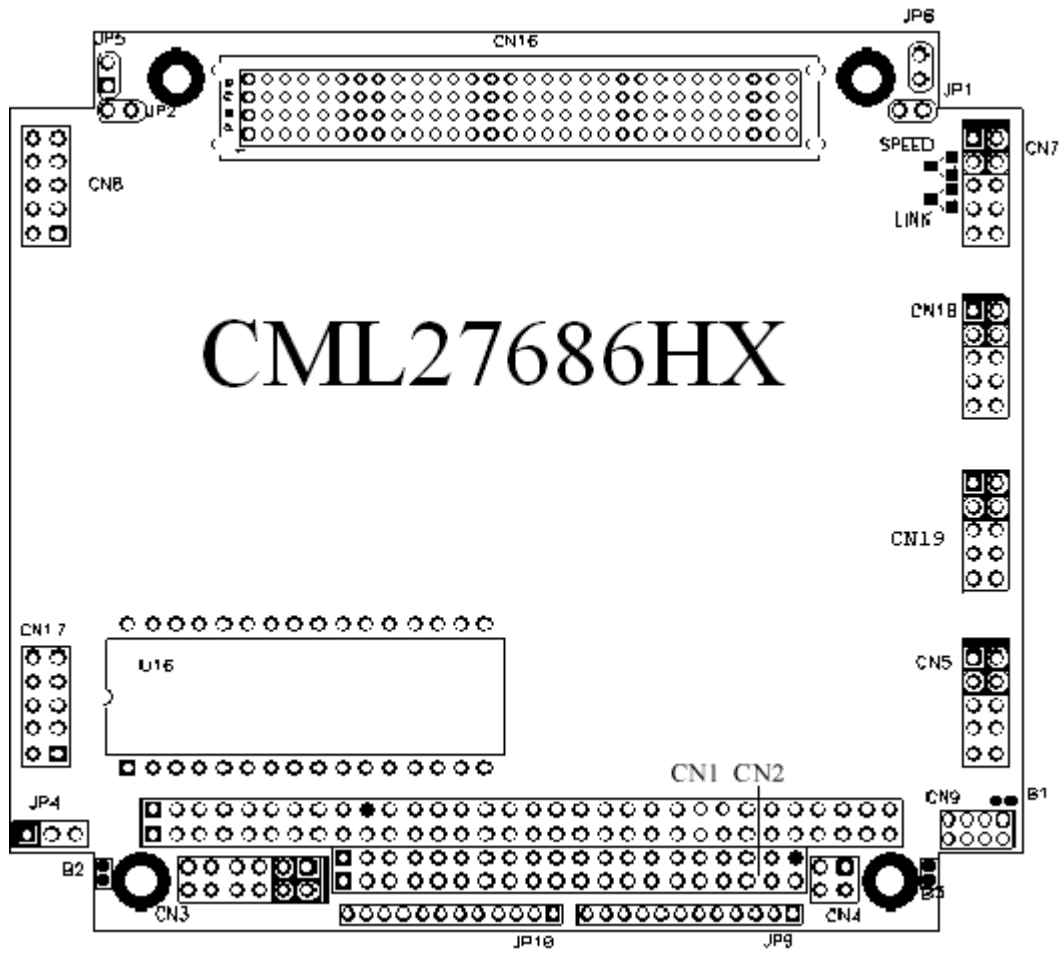

Jumpers and Default Jumper Settings

JP1	2-pin jumper Used to enable/disable 120 ohm termination resistor on first serial port for RS-422/485 mode. default: Open (no termination)
JP2	2-pin jumper Used to enable/disable 120 ohm termination resistor on first serial port for RS-422/485 mode. default: Open (no termination)
JP4	3-pin jumper Used to select power for an SSD socket. 1 to 2 is 5 Volts on board. 2 to 3 is 5 volts on board when power on and battery backup when power off default: Positions 1 and 2.
JP5	2-pin jumper Used for setting to boot to Fail Safe Boot ROM default: Open
JP6	2-pin jumper Factory use only; do not close. default: Open

686GX Processor Thermal Management

The industrial grade processor IC of the cpuModule must receive adequate cooling to ensure proper operation and good reliability. The case temperature of the processor must not exceed +85°C. The processor is therefore supplied with an attached fan or heatsink with a thermal resistance of 5° C/W.

NOTE!	This cpuModule is <i>not</i> warranted against damage caused by overheating due to improper or insufficient heatsinking or airflow.
--------------	---

The table below shows the maximum ambient temperature allowed vs. θ_{CA} .

Case Temperature 85° C		θ_{CA} for Different Ambient Temperatures (°C/W)				
Part Number	Frequency	20° C	25° C	30° C	35° C	40° C
CML27686HX300	300 MHz	17	16	15	13	12
CML27686HX333	333 MHz	13	12	11	10	9

CHAPTER 7: TROUBLESHOOTING

Many problems you may encounter with operation of your cpuModule are due to common errors. This chapter will help you get your system operating properly.

It contains:

- Common problems and solutions
- Troubleshooting a PC/104 system
- How to obtain technical support
- How to return a product

Common Problems and Solutions

The following table lists some of the common problems you may encounter while using your cpuModule, and suggests possible solutions.

If you are having problems with your cpuModule, please review this table *before* contacting technical support.

Problem	Cause	Solution
cpuModule "will not boot"	no power or wrong polarity	check for correct power on PC/104 bus connectors
	incorrect Setup (video disabled, etc.)	reboot and press {Del} key to run Setup
	defective or mis-connected device on bus	check for misaligned bus connectors; remove other cards from stack
	cable connected backwards	verify all cables are connected correctly
	SSD installed backwards	check for an SSD memory installed in socket backwards
will not boot from particular drive or device	device not bootable	use sys command on drive or re-format the device using the /s switch
	device not formatted	format drive using /s switch
	power not connected to boot drive	connect power cable to floppy or hard drive
Atmel Flash shows disk space available, but it cannot be written	part smaller than 1.44MB was formatted as 1.44MB; it will show space available even when full	ignore "disk space remaining" messages from DOS REMEMBER! A bootable disk contains 3 hidden files plus format info, totalling about 150kB
will not boot from DiskOnChip®	DiskOnChip® is not the only hard drive in system	disable other hard drive(s) in system
	using wrong DiskOnChip® device (not 32 pin)	change to correct (32 pin) DiskOnChip®
	Boot device not set to Hard disk	run Setup and set boot device to Hard Drive

erratic operation	excessive bus loading	reduce number of PC/104 modules in stack; remove termination components from bus signals; remove any power supply bus terminations
	power supply noise	examine power supply output with oscilloscope; glitches below 4.75Vdc will trigger a reset; add bypass caps
	power supply limiting	examine power supply output with oscilloscope; check for voltage drop below 4.75V when hard drive or floppy drive starts; add bypass caps
	temperature too high	add fan, processor heatsink, or other cooling device(s) <i>See 686GX Processor Thermal Management.</i>
	memory address conflict	check for two hardware devices (e.g. Ethernet, SSD, Arcnet, PCMCIA) trying to use the same memory address check for two software devices (e.g. EMM386, PCMCIA drivers, etc.) trying to use the same memory addresses check for hardware and software devices trying to use the same memory address check for an address range shadowed (see Advanced Setup screen) while in use by another hardware or software device
	I/O address conflict	check for another module trying to use I/O addresses reserved for the cpuModule between 010h and 01Fh check for two modules (e.g. dataModules, PCMCIA cards, Ethernet) trying to use the same I/O addresses
keyboard does not work	keyboard interface damaged by misconnection	check if keyboard LEDs light
	wrong keyboard type	verify keyboard is an 'AT' type or switch to 'AT' mode
Windows 3.1x installation program hangs	smartdrive enabled	remove smartdrive command from config.sys, reboot, run install program
floppy drive light always on	cable misconnected	check for floppy drive cable connected backwards

two hard drives will not work, but one does	both drives configured for master	set one drive for master and the other for slave operation (consult drive documentation)
floppy does not work	"data error" due to drive upside down	orient drive properly (upright or on its side)
will not boot when video card is removed	illegal calls to video controller	look for software trying to access non-existent video controller for video, sound, or beep commands
won't boot from PCMCIA hard drive	booting from PCMCIA is not supported	boot from SSD, use autoexec.bat to load PCMCIA drivers, run application from PCMCIA card
COM port will not work in RS422 or RS485 modes	not configured for RS422/485	correctly configure serial port in Setup program
COM port will not transmit in RS422 or RS485 mode	not enabling transmitters	control RTS* bit of Modem Control Register to enable transmitters; see Serial Port descriptions
date and time not saved when power is off	no backup battery	connect a backup battery to the Multifunction connector
cannot enter bios	quick boot enabled with no hard drives	install JP5, reboot, and run qboot.exe and reboot.

Troubleshooting a PC/104 System

If you have reviewed the preceding table and still cannot isolate the problem with your cpuModule, please try the following troubleshooting steps. Even if the resulting information does not help you find the problem, it will be very helpful if you contact technical support.

Simplify the system. Remove items one at a time and see if one particular item seems to cause the problem.

Swap components. Try replacing items in the system one-at-a-time with similar items.

How to Obtain Technical Support

If after following the above steps, you still cannot resolve a problem with your cpuModule, please assemble the following information:

- cpuModule **model**, **BIOS version**, and serial number
- list of **all boards in system**
- list of settings from cpuModule Setup program
- printout of autoexec.bat and config.sys files (if applicable)
- description of problem
- circumstances under which problem occurs

Then contact factory technical support:

Phone: 814 234-8087
Fax: 814 234-5218
E-mail: techsupport@rtd.com

How to Return a Product

NOTE!	You <i>must</i> have authorization from the factory in the form of an RMA# before returning <i>any</i> item for <i>any</i> reason!
--------------	--

If you wish to return a product to the factory for service, please follow this procedure:

- 1) Read the Limited Warranty to familiarize yourself with our warranty policy.
- 2) Please have the following available
 - Complete board name
 - Board serial number
 - A detailed description of the board's behavior
- 1) Contact the factory for a Return Merchandise Authorization (RMA) number.
- 2) **Write a detailed description** of the situation or problem.
Include as much information as possible!
- 3) **List the name of a contact person**, familiar with technical details of the problem or situation, **along with their phone and fax numbers, address, and e-mail address** (if available).
- 4) **List your shipping address!**
- 5) Indicate the shipping method you would like used to return the product to you.
We will not ship by next-day service without your pre-approval.
- 6) Carefully package the product, *using proper anti-static packaging.*
- 7) Write the RMA number in large (1") letters on the outside of the package.
- 8) Return the package to:
RTD Embedded Technologies, Inc.
103 Innovation Blvd.
State College PA 16803-0906
USA

CHAPTER 8: LIMITED WARRANTY

RTD Embedded Technologies, Inc. warrants the hardware and software products it manufactures and produces to be free from defects in materials and workmanship for one year following the date of shipment from RTD Embedded Technologies, INC. This warranty is limited to the original purchaser of product and is not transferable.

During the one year warranty period, RTD Embedded Technologies will repair or replace, at its option, any defective products or parts at no additional charge, provided that the product is returned, shipping prepaid, to RTD Embedded Technologies. All replaced parts and products become the property of RTD Embedded Technologies. Before returning any product for repair, customers are required to contact the factory for an RMA number.

THIS LIMITED WARRANTY DOES NOT EXTEND TO ANY PRODUCTS WHICH HAVE BEEN DAMAGED AS A RESULT OF ACCIDENT, MISUSE, ABUSE (such as: use of incorrect input voltages, improper or insufficient ventilation, failure to follow the operating instructions that are provided by RTD Embedded Technologies, "acts of God" or other contingencies beyond the control of RTD Embedded Technologies), OR AS A RESULT OF SERVICE OR MODIFICATION BY ANYONE OTHER THAN RTD Embedded Technologies. EXCEPT AS EXPRESSLY SET FORTH ABOVE, NO OTHER WARRANTIES ARE EXPRESSED OR IMPLIED, INCLUDING, BUT NOT LIMITED TO, ANY IMPLIED WARRANTIES OF MERCHANTABILITY AND FITNESS FOR A PARTICULAR PURPOSE, AND RTD Embedded Technologies EXPRESSLY DISCLAIMS ALL WARRANTIES NOT STATED HEREIN. ALL IMPLIED WARRANTIES, INCLUDING IMPLIED WARRANTIES FOR MERCHANTABILITY AND FITNESS FOR A PARTICULAR PURPOSE, ARE LIMITED TO THE DURATION OF THIS WARRANTY. IN THE EVENT THE PRODUCT IS NOT FREE FROM DEFECTS AS WARRANTED ABOVE, THE PURCHASER'S SOLE REMEDY SHALL BE REPAIR OR REPLACEMENT AS PROVIDED ABOVE. UNDER NO CIRCUMSTANCES WILL RTD Embedded Technologies BE LIABLE TO THE PURCHASER OR ANY USER FOR ANY DAMAGES, INCLUDING ANY INCIDENTAL OR CONSEQUENTIAL DAMAGES, EXPENSES, LOST PROFITS, LOST SAVINGS, OR OTHER DAMAGES ARISING OUT OF THE USE OR INABILITY TO USE THE PRODUCT.

SOME STATES DO NOT ALLOW THE EXCLUSION OR LIMITATION OF INCIDENTAL OR CONSEQUENTIAL DAMAGES FOR CONSUMER PRODUCTS, AND SOME STATES DO NOT ALLOW LIMITATIONS ON HOW LONG AN IMPLIED WARRANTY LASTS, SO THE ABOVE LIMITATIONS OR EXCLUSIONS MAY NOT APPLY TO YOU.

THIS WARRANTY GIVES YOU SPECIFIC LEGAL RIGHTS, AND YOU MAY ALSO HAVE OTHER RIGHTS WHICH VARY FROM STATE TO STATE.

RTD Embedded Technologies, Inc.
103 Innovation Blvd.
State College PA 16803-0906
USA
Our website: www.rtd.com

