

CMT103HR IDE Controller and Flash Drive Carrier utilityModule

User's Manual

Hardware Revision 1.0

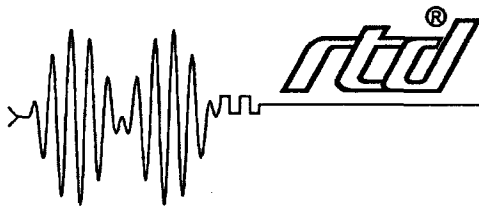

Real Time Devices, Inc.

"Accessing the Analog World"®

Publication No. CMT103HR 98.06.25

ISO9001 and AS9100 Certified

CMT103HR
IDE Controller and Flash Drive Carrier
utilityModule
User's Manual

REAL TIME DEVICES USA, INC.
PO Box 906
200 Innovation Blvd.
State College, PA 16804-0906 USA

Phone: (814) 234-8087
FAX: (814) 234-5218

E-Mail
sales@rtdusa.com
techsupport@rtdusa.com

Website
<http://www.rtdusa.com>

Notice: We have attempted to verify all information in this manual is correct as of the publication date. Information in this manual may change without prior notice from Real Time Devices USA.

Published by
Real Time Devices USA, Inc.
200 Innovation Blvd.
P.O. Box 906
State College, PA 16804-0906 USA

Copyright 1998 by Real Time Devices USA, Inc.
All rights reserved
Printed in U.S.A.

PC/XT, PC/AT are registered trademarks of IBM Corporation.
PC/104 is a registered trademark of PC/104 Consortium.
The Real Time Devices Logo is a registered trademark of Real Time Devices.
utilityModule is a trademark of Real Time Devices.
All other trademarks appearing in this document are the property of their respective owners.

Table of Contents

CHAPTER 1 INTRODUCTION	1
FEATURES	1
CHAPTER 2 CONFIGURING THE UTILITYMODULE	3
JUMPERS.....	3
CHAPTER 3 INSTALLING THE UTILITYMODULE	5
RECOMMENDED PROCEDURE	5
CHAPTER 4 CONNECTING THE UTILITYMODULE	6
PC/104 BUS CONNECTORS, CN1 AND CN2	7
IDE, CN3.....	9
FLASH DRIVE, CN4.....	11
CHAPTER 5 USING THE UTILITYMODULE.....	12
FLASH HARD DISK	13
POWER PROTECTION CIRCUITRY.....	14
CHAPTER 6 INTERFACING FLASH DRIVES.....	16
CONNECTING THE CMT103HR TO A COMPUTER WITH AN IDE CONTROLLER AS THE ONLY IDE DRIVE.....	16
CONNECTING THE CMT103HR TO A COMPUTER WITHOUT AN IDE CONTROLLER AS THE ONLY IDE DRIVE	16
CONNECTING THE CMT103HR TO A COMPUTER AS THE SECONDARY MASTER IDE DRIVE CONTROLLER.....	16
USING A CMT103HR AS A SLAVE DRIVE ON A COMPUTER WITH AN IDE CONTROLLER AND A MASTER DRIVE	17
USING A CMT103HR AS A SLAVE DRIVE ON A COMPUTER WITHOUT AN IDE CONTROLLER AND ANOTHER CMT103HR AS A MASTER DRIVE	17
CHAPTER 7 RETURN POLICY AND WARRANTY.....	18
RETURN POLICY	18
LIMITED WARRANTY	19

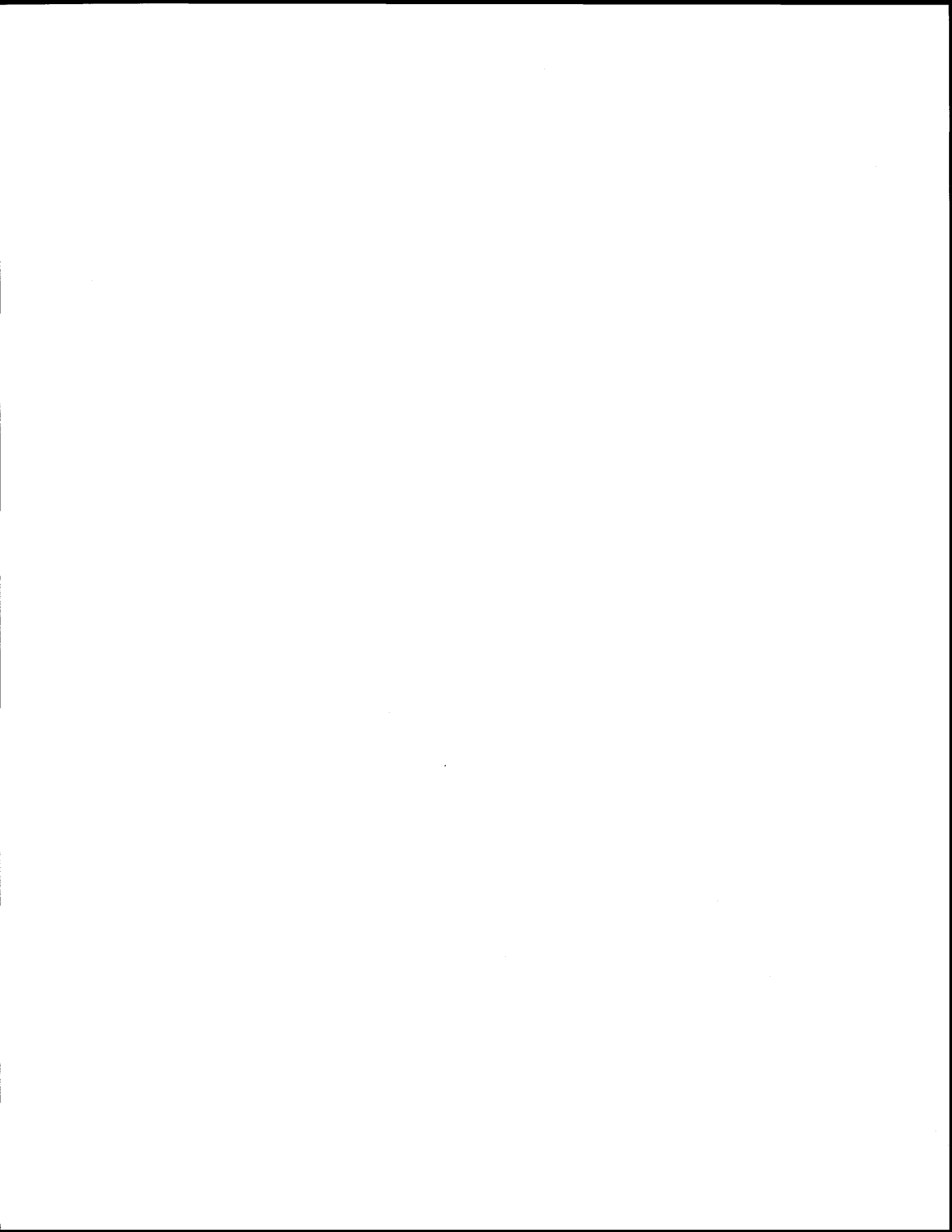

Chapter 1 INTRODUCTION

This manual gives information on the CMT103HR IDE Controller and Flash Disk Carrier utilityModule. This module mounts 1.8" ATA Flash Drives in the PC/104 stack.

CMT103HR IDE and Flash Drive Carrier utilityModule

The CMT103HR utilityModule was designed to provide a Flash drive in the PC/104 stack to support the Real Time Devices cpuModules and other standard PC/104 processor modules.

Features

The following are major features of the CMT103HR utilityModule.

Supplied with a SanDisk 20 MB Industrial grade Flash Drive.

Allows up to four drives in the PC/104 stack. Supports 1.8" Flash drives such as SanDisk

Jumper selection of bus or cabled operation

- Bus mode -- decodes IDE interface through the PC/104 bus for cableless operation

IDE mode -- attaches drive to a cpuModules IDE interface and to attach a slave to a master drive

Jumper selection of primary or secondary IDE interface in bus mode

- Primary -- IDE Interface at 1F0-1F7h
- Secondary -- IDE Interface at 170-177h

Jumper selection of master or slave drive

- Master -- for the first drive on each interface
- Slave -- for the second drive on each interface

Connectors

Connectors provided are:

- CN1: PC/104 Bus (XT)
- CN2: PC/104 Bus (AT)
- CN3: IDE cable
- CN4: 1.8" Flash Drive connector

Recommended Cables

- The CMT103HR requires a 40-pin IDE cable to connect a master CMT103HR to a slave CMT103HR or to connect a CMT103HR in IDE mode to a CPU IDE adapter.

General Specifications

- Dimensions: 3.8 x 3.9 x 0.6" (97 x 100 x 16 mm)
- Weight (mass): 3.0 ounces (85 grams)
- 4-layer PCB
- Operating conditions: (including standard drive)
 - temperature: -20 - +85 degrees C
 - relative humidity: 0 - 95%, non-condensing
 - Storage temperature: -55 to +125 degrees C

Chapter 2 CONFIGURING THE UTILITYMODULE

The following sections contain information on configuring the utilityModule.

Please read this entire section before attempting to use the utilityModule!

Jumpers

Jumper JP1 configures the following functions:

- Master/Slave
- Bus/Cabled
- Primary/Secondary

Default Settings

The utilityModule is delivered from the factory configured according to the following table.

Setting	Function
1-2 Open	Master Drive
1-2 Closed	Slave Drive
3-4 Open	Reserved

BUS	Decode IDE Through PC/104 bus
IDE	Use CN3 for IDE interface

If BUS mode is selected then:

PRI	Primary IDE interface
SEC	Secondary IDE interface

-
- Notes:**
1. Position 3-4 must be left open.
 2. You must select only one of BUS or IDE.
 3. If you have selected BUS, you must select only one of PRI or SEC.
-

Jumper Locations

The figure below shows jumper locations.

JP1

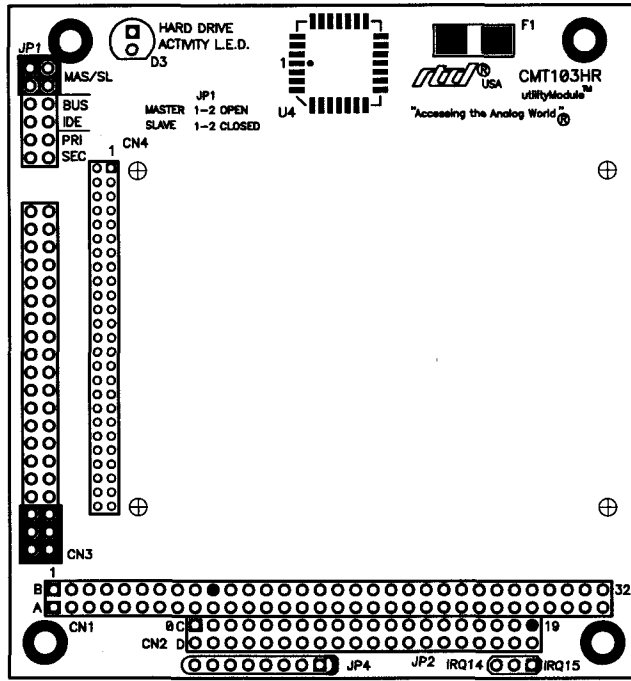

Jumper Locations

Chapter 3 INSTALLING THE UTILITYMODULE

Since the utilityModule uses a PC/104 stackthrough bus, the only hardware installation you will do is placing the module to the PC/104 stack. To do this, you will connect the PC/104 bus connector with the matching connector of another module.

Recommended Procedure

We recommend you follow the procedure below to ensure that stacking of the modules does not damage connectors or electronics.

- Turn off power to the PC/104 system or stack.
- Select and install standoffs to properly position the utilityModule on the PC/104 stack.
- Touch a grounded metal part of the stack to discharge any buildup of static electricity.
- Remove the utilityModule from its anti-static bag.
- Check that keying pins in the PC/104 bus connector are properly positioned.
- Check the stacking order: make sure an XT bus card will not be placed between two AT bus cards, or it will interrupt the AT bus signals.
- Hold the utilityModule by its edges and orient it so the bus connector pins line up with the matching connector on the stack.
- Gently and evenly press the utilityModule onto the PC/104 stack.

CAUTION: Do not force the module onto the stack! Wiggling the module or applying too much force may damage it. If the module does not readily press into place, remove it, check for bent pins or out-of-place keying pins, and try again.

Chapter 4 CONNECTING THE UTILITYMODULE

The following sections describe connectors of the utilityModule.

Finding Pin 1 of Connectors

The pin 1 end of connectors is indicated by a white area silk-screened on the PC board. It is also indicated by a square solder pad visible on the bottom of the PC board.

Please make certain you have correctly identified pin 1 of a connector before you connect to it and attempt to use the utilityModule.

Connector Locations

The figure below shows connector locations.

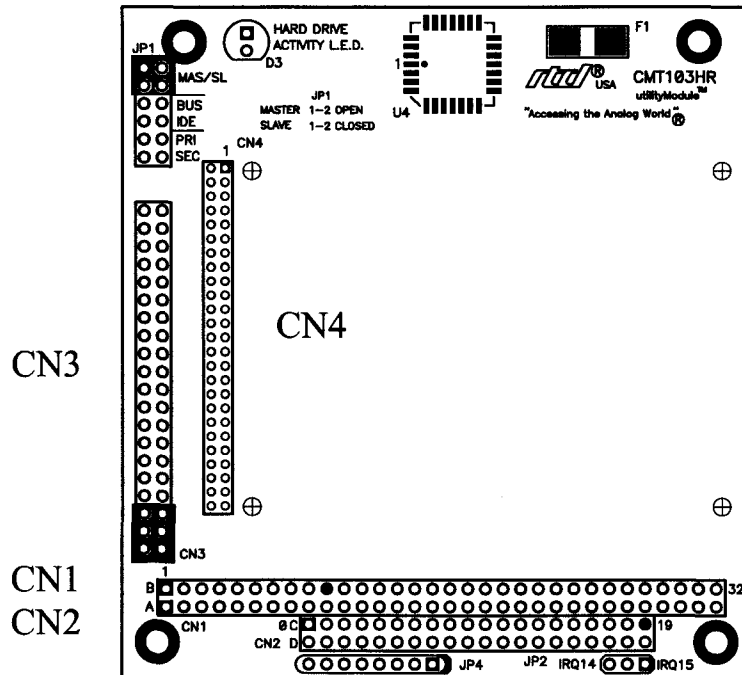

Connector Locations

Connectors		
Connector	Function	Size
CN1	PC/104 XT Bus	64 pin
CN2	PC/104 AT Bus	40 pin
CN3	IDE Connector	40 pin
CN4	2 mm Flash Drive Connector	68 pin

PC/104 Bus Connectors, CN1 and CN2

Connectors CN1 and CN2 provide PC/104 bus connections. CN1 carries XT bus signals, and CN2 carries additional signals for the AT bus. The signals on CN1 and CN2 conform to the IEEE P966 standard for the PC/104 bus.

The following tables list the connector pinouts:

PC/104 XT Bus Connector, CN1		
Pin	Row A	Row B
1	IOCHCHK*	0V
2	SD7	RESETDRV
3	SD6	+5V
4	SD5	IRQ9
5	SD4	-5V
6	SD3	DRQ2
7	SD2	-12V
8	SD1	ENDXFR*
9	SD0	+12V
10	IOCHRDY	(KEYING PIN)
11	AEN	SMEMW*
12	SA19	SMEMR*
13	SA18	IOW*
14	SA17	IOR*
15	SA16	DACK3
16	SA15	DRQ3
17	SA14	DACK1*
18	SA13	DRQ1
19	SA12	REFRESH
20	SA11	SYSCLK
21	SA10	IRQ7
22	SA9	IRQ6
23	SA8	IRQ5
24	SA7	IRQ4
25	SA6	IRQ3
26	SA5	DACK2*
27	SA4	TC
28	SA3	BALE
29	SA2	+5V
30	SA1	OSC
31	SA0	0V
32	0V	0V

PC/104 AT Bus Connector, CN2		
Pin	Row C	Row D
0	0V	0V
1	SBHE*	MEMCS16*
2	LA23	IOCS16*
3	LA22	IRQ10
4	LA21	IRQ11
5	LA20	IRQ12
6	LA19	IRQ15
7	LA18	IRQ14
8	LA17	DACK0*
9	MEMR*	DRQ0
10	MEMW*	DACK5*
11	SD8	DRQ5
12	SD9	DACK6*
13	SD10	DRQ6
14	SD11	DACK7*
15	SD12	DRQ7
16	SD13	+5V
17	SD14	MASTER*
18	SD15	0V
19	(KEYING PIN)	0V

Note: Two locations on the bus have mechanical keying pins to help prevent misconnection of the PC/104 bus. These keying pins are a part of the PC/104 standard, and we strongly recommend you leave them in place.

If you have other modules without keying pins, we suggest you modify them to include keying.

IDE, CN3

CN3 is a 40-pin 0.1" DIL connector is the IDE input connector in IDE mode and the IDE output in BUS mode. The pinout of this connector is shown below.

IDE Hard Drive Connector, CN3			
Pin	Signal	Function	in/out
1	RESET*	Reset HD	out
2	GND	Ground signal	--
3	HD7	HD data 7	in/out
4	HD8	HD data 8	in/out
5	HD6	HD data 6	in/out
6	HD9	HD data 9	in/out
7	HD5	HD data 5	in/out
8	HD10	HD data 10	in/out
9	HD4	HD data 4	in/out
10	HD11	HD data 11	in/out
11	HD3	HD data 3	in/out
12	HD12	HD data 12	in/out
13	HD2	HD data 2	in/out
14	HD13	HD data 13	in/out
15	HD1	HD data 1	in/out
16	HD14	HD data 14	in/out
17	HD0	HD data 0	in/out
18	HD15	HD data 15	in/out
19	GND	Ground signal	--
20	n.c.		--
21	AEN	Address Enable	out
22	GND	Ground signal	--
23	IOW*	I/O Write	out
24	GND	Ground signal	--
25	IOR*	I/O Read	out
26	GND	Ground signal	--
27	IOCHRDY	I/O Channel Ready	in
28	BALE	Bus Address Latch Enable	out
29	n.c.		
30	GND	Ground signal	--
31	IRQ	Interrupt Request	in
32	IOCS16*	16 bit transfer	in
33	A1	Address 1	out
34	GND	Ground signal	--
35	A0	Address 0	out
36	A2	Address 2	out

37	HCS0*	HD Select 0	out
38	HCS1*	HD Select 1	out
39	LED	HDD activity LED (-)	in
40	GND	Ground signal	--

Flash Drive, CN4

The 50 pin Flash Drive connector is to connect hard drives and Flash ATA cards.
This works with SanDisk Flash Drives.

Chapter 5 USING THE UTILITYMODULE

Flash Hard Disk

In general, IBM-PC computers support two IDE interfaces. Each interface can support a master and a slave IDE drive which allows up to 4 drives in a computer (assuming that the CPU BIOS supports 4 drives).

The CMT103HR operates as a drive carrier to convert the 50 pin 2 mm connector on 1.8" Flash drives to the standard 40 pin IDE connector and provide a master/slave jumper. It can also be an IDE controller for computers without an IDE interface or to add a secondary IDE interface to a computer that only has one. These two modes of operation are selected by installing one of the IDE or BUS jumpers.

The hard drive controller of the utilityModule appears as a standard PC IDE hard drive controller. It will support standard IDE drives (less than 528MB) and enhanced IDE drives (over 528MB).

You may need to run the setup program for your cpuModule or computer to configure the correct hard drive type.

IDE Mode

The PC/104 bus only provides power to the drive. The board performs a physical interface between the 50 pin 2 mm connector and the 40 pin IDE connector. The JP1 pins 1-2 jumpers select master or slave mode for the drive.

BUS Mode

This mode decodes the PC/104 bus to create an IDE interface. This interface can be the primary or secondary interface and the drive can be a master or slave as per the jumpers. The 40 pin IDE connector is used to connect a second drive to this interface. The second drive can be a standard 3.5" drive or another CMT103HR or CMT104 operating in IDE mode.

Power Protection Circuitry

To reduce the risk of damage due to power-supply problems, the utilityModule includes several protective components.

Module Power-Supply Protection

The utilityModule includes components to help prevent damage due to problems with the +5Vdc power supply from the PC/104 bus or power-supply connector. Protection is provided for:

- Over-current
- Reversed polarity
- Excessive voltage

This protection is only for the utilityModule, and will not protect other devices in a PC/104 stack.

The protective fuse is replaceable and is available from electronics suppliers. Its description and part number are:

Littelfuse Nano² SMF 1.0 amp, R451-001

Caution: Replace fuses only with parts of identical current and voltage rating.

Chapter 6 INTERFACING FLASH DRIVES

The utilityModule can be configured in several methods.

Connecting the CMT103HR to a computer with an IDE controller as the only IDE drive

- Install IDE jumper
- Remove BUS jumper
- Install PRI jumper (Not used since in IDE mode)
- Remove SEC jumper (Not used since in IDE mode)
- Connect a 40 pin cable from CPU's IDE connector to the CMT103HR IDE connector CN3, be careful to observe pin 1 orientation
- Remove jumper JP1 pins 1-2 to select master (pins 3-4 should be always open)
- Use the CPU's setup utility to configure the heads, cylinders and sectors for primary master drive

Connecting the CMT103HR to a computer without an IDE controller as the only IDE drive

- Install BUS jumper
- Remove IDE jumper
- Install PRI jumper
- Remove SEC jumper
- Remove jumper JP1 pins 1-2 to select master (pins 3-4 should be always open)
- Use the CPU's setup utility to configure the heads, cylinders and sectors for primary master drive

Connecting the CMT103HR to a computer as the secondary master IDE drive controller

- Install BUS jumper
- Remove IDE jumper
- Install SEC jumper
- Remove PRI jumper
- Remove jumper JP1 pins 1-2 to select master (pins 3-4 should be always open)
- Use the CPU's setup utility to configure the heads, cylinders and sectors for secondary master drive

Using a CMT103HR as a slave drive on a computer with an IDE controller and a master drive

- Install IDE jumper
- Remove BUS jumper
- Install PRI jumper (Not used since in IDE mode)
- Remove SEC jumper (Not used since in IDE mode)
- Connect a three connector 40 pin cable from CPU's IDE connector to the master drive and to the CMT103HR IDE connector CN3, be careful to observe pin 1 orientation
- Install jumper JP1 pins 1-2 to select slave (pins 3-4 should be always open)
- Use the CPU's setup utility to configure the heads, cylinders and sectors for the primary or secondary slave drive

Using a CMT103HR as a slave drive on a computer without an IDE controller and another CMT103HR as a master drive

Set the Master drive as above then set the slave as follows:

- Install IDE jumper
- Remove BUS jumper
- Install PRI jumper (Not used since in IDE mode)
- Remove SEC jumper (Not used since in IDE mode)
- Install jumper JP1 pins 1-2 to select slave (pins 3-4 should be always open)
- Connect a 40 pin cable from the master CMT103HR IDE connector CN3 to the slave CMT103HR IDE connector CN3, be careful to observe pin 1 orientation
- Use the CPU's setup utility to configure the heads, cylinders and sectors for primary or secondary slave drive

Chapter 7 RETURN POLICY AND WARRANTY

Return Policy

If the utilityModule requires repair, you may return it to us by following the procedure listed below:

Caution: Failure to follow this return procedure will *almost always* delay repair!
Please help us expedite your repair by following this procedure.

- 1) Read the limited warranty which follows.
- 2) Contact the factory and request a Returned Merchandise Authorization (RMA) number.
- 3) On a sheet of paper, write the name, phone number, and fax number of a technically-competent person who can answer questions about the problem.
- 4) On the paper, write a detailed description of the problem with the product. Answer the following questions:
 - Did the product ever work in your application?
 - What other devices were connected to the product?
 - How was power supplied to the product?
 - What features did and did not work?
 - What was being done when the product failed?
 - What were environmental conditions when the product failed?
- 5) Indicate the method we should use to ship the product back to you.
 - We will return warranty repairs by UPS Ground at our expense.
 - Warranty repairs may be returned by a faster service at your expense.
 - Non-warranty repairs will be returned by UPS Ground or the method you select, and will be billed to you.
- 6) Clearly specify the address to which we should return the product.
- 7) Enclose the paper with the product being returned.
- 8) Carefully package the product to be returned *using anti-static packaging!* We will not be responsible for products damaged in transit for repair.
- 7) Write the RMA number on the outside of the package.
- 8) Ship the package to:

Real Time Devices
200 Innovation Blvd.
State College PA 16803
USA

Limited Warranty

Real Time Devices, Inc. warrants the hardware and software products it manufactures and produces to be free from defects in materials and workmanship for one year following the date of shipment from REAL TIME DEVICES, USA. This warranty is limited to the original purchaser of product and is not transferable.

During the one year warranty period, REAL TIME DEVICES USA will repair or replace, at its option, any defective products or parts at no additional charge, provided that the product is returned, shipping prepaid, to REAL TIME DEVICES USA. All replaced parts and products become the property of REAL TIME DEVICES USA. Before returning any product for repair, customers are required to contact the factory for an RMA number.

THIS LIMITED WARRANTY DOES NOT EXTEND TO ANY PRODUCTS WHICH HAVE BEEN DAMAGED AS A RESULT OF ACCIDENT, MISUSE, ABUSE (such as: use of incorrect input voltages, improper or insufficient ventilation, failure to follow the operating instructions that are provided by REAL TIME DEVICES USA, "acts of God" or other contingencies beyond the control of REAL TIME DEVICES USA), OR AS A RESULT OF SERVICE OR MODIFICATION BY ANYONE OTHER THAN REAL TIME DEVICES USA. EXCEPT AS EXPRESSLY SET FORTH ABOVE, NO OTHER WARRANTIES ARE EXPRESSED OR IMPLIED, INCLUDING, BUT NOT LIMITED TO, ANY IMPLIED WARRANTIES OF MERCHANTABILITY AND FITNESS FOR A PARTICULAR PURPOSE, AND REAL TIME DEVICES EXPRESSLY DISCLAIMS ALL WARRANTIES NOT STATED HEREIN. ALL IMPLIED WARRANTIES, INCLUDING IMPLIED WARRANTIES FOR MERCHANTABILITY AND FITNESS FOR A PARTICULAR PURPOSE, ARE LIMITED TO THE DURATION OF THIS WARRANTY. IN THE EVENT THE PRODUCT IS NOT FREE FROM DEFECTS AS WARRANTED ABOVE, THE PURCHASER'S SOLE REMEDY SHALL BE REPAIR OR REPLACEMENT AS PROVIDED ABOVE. UNDER NO CIRCUMSTANCES WILL REAL TIME DEVICES BE LIABLE TO THE PURCHASER OR ANY USER FOR ANY DAMAGES, INCLUDING ANY INCIDENTAL OR CONSEQUENTIAL DAMAGES, EXPENSES, LOST PROFITS, LOST SAVINGS, OR OTHER DAMAGES ARISING OUT OF THE USE OR INABILITY TO USE THE PRODUCT.

SOME STATES DO NOT ALLOW THE EXCLUSION OR LIMITATION OF INCIDENTAL OR CONSEQUENTIAL DAMAGES FOR CONSUMER PRODUCTS, AND SOME STATES DO NOT ALLOW LIMITATIONS ON HOW LONG AN IMPLIED WARRANTY LASTS, SO THE ABOVE LIMITATIONS OR EXCLUSIONS MAY NOT APPLY TO YOU.

THIS WARRANTY GIVES YOU SPECIFIC LEGAL RIGHTS, AND YOU MAY ALSO HAVE OTHER RIGHTS WHICH VARY FROM STATE TO STATE.